

Preface	Manufacturing Specification	Performance Data	Pipes and Fittings – ANSI	Pipes and Fittings – DIN	PTFE expansion bellows	
Sight Flow Indicator	Spectacle Blinds	Ball Check Valve	Level Indicator	Dip Pipes	Nozzle linings	Column Internals

#SURELINE

TECHNICAL MANUAL

Fluoropolymer Lined Products

PTFE - PFA - FEP - ECTFE - PVDF

Preface	2
Manufacturing Specification	3
Performance Data	8
Pipes and Fittings – ANSI	16
Pipes and Fittings – DIN	35
PTFE expansion bellows	54
Sight Flow Indicator	61
Spectacle Blinds	62
Ball Check Valve	63
Level Indicator	64
Dip Pipes	65
Nozzle linings	66
Column Internals	67

Preface	Manufacturing Specification	Performance Data	Pipes and Fittings – ANSI	Pipes and Fittings – DIN	PTFE expansion bellows	
Sight Flow Indicator	Spectacle Blinds	Ball Check Valve	Level Indicator	Dip Pipes	Nozzle linings	Column Internals

#SURELINE

PIPE SYSTEMS

MB Plastics – Fluoropolymer Division – A recognised European leader in the field of fluoropolymer and thermoplastic liners, offers a unique complete design, manufacture and installation package for fluoropolymer lined steel pipe systems and vessels.

The combination of relatively expensive, high performance fluoropolymer materials such as PTFE with an economical high strength carbon steel pipe or vessel structure, results in an overall economical solution to many problems concerning the handling and storage of a wide range of aggressive fluids or ultra-pure liquids.

The range of materials used as a liner include,

- **PTFE** – (Polytetrafluoroethylene), the oldest fluorocarbon resin, discovered in 1941, with exceptional resistance to practically all chemicals, but requiring an extremely high level of expertise in welding and thermoforming technologies.
- **PFA** – (Perfluoro-alkoxy), a more recent development, having a similar chemical resistance to that of PTFE, but offering improved welding and thermoforming properties.
- **FEP** – (Fluorinated ethylene propylene), with similar chemical resistance to that of PTFE but with improved welding and forming properties. Both PFA and FEP have lower operating temperatures than PTFE, but all three meet the requirements for maximum operating temperatures of both bonded and non-bonded liners
- **PVDF** – (Polyvinylidene fluoride), generally offers the weldability of polypropylene combined with a significant improvement in chemical resistance.
- **E-CTFE** – (Ethylene-chlorotrifluoroethylene) offers a high level of chemical resistance, good working properties and high levels of purity.
- **PP** – (Polypropylene), offers a reasonable level of chemical and temperature resistance, combined with excellent working properties.

With more than 20 years of experience in this field, MB Plastics is well known as a leader in the field of welding, thermoforming and lining with the full and ever expanding range of fluoropolymer and high performance thermoplastic materials, and is in the enviable position to offer not only steel lined pipe systems and structures, but also, with the assistance of the composite and thermoplastic activities within the MB Plastics organisation, a full range of dual laminate products. These may range from PVC or PVC-C pipe systems or vessels, through structures using polypropylene or polyethylene liners, up to the high performance PVDF based products, and finally the fluoropolymers such as E-CTFE, FEP and PFA, all reinforced with the most appropriate thermosetting resin based composite structure, obtained by either filament winding or contact moulding.

No other European company is in a position to offer this unique range of products, nor the capacity to handle projects involving both vessels and pipe systems, working with the client to evaluate the performance of the different materials, designing the vessel and the detailed configuration of the pipe system, manufacturing the equipment and handling the installation on any site in the world, and finally testing and handing over the finished project.

Preface	Manufacturing Specification	Performance Data	Pipes and Fittings – ANSI	Pipes and Fittings – DIN	PTFE expansion bellows
Sight Flow Indicator	Spectacle Blinds	Ball Check Valve	Level Indicator	Dip Pipes	Nozzle linings
					Column Internals

#SURELINE

PIPE SYSTEMS

This specification covers materials, manufacturing, testing, inspection and packaging standards for MB Plastics #Sureline Heavy duty PTFE/PFA ANSI lined pipe system.

Materials of construction

All materials used shall be traceable to origin and records shall be maintained for a minimum of five years. When specified, material and/or test certificates shall be supplied.

Lining

Pipe spools shall be lined with PTFE.

Fittings shall be lined with PTFE or PFA.

PTFE

PTFE lining shall be made from resin conforming to the requirements of ASTM D1457 types I, III, IV or VI, ASTM D4894 or ASTM D4895.

The PTFE resin shall be virgin material. Reworked material is not permitted.

When tested in accordance with the specification, the minimum tensile strength and elongation at break shall be: 20.7 N/mm² and 250 per cent for extruded material.

17.2 N/mm² and 250 per cent for isostatically moulded material.

The SG of the PTFE material shall be in the range 2.15 to 2.19 when tested to ASTM D792 or D1505.

PFA

PFA lining shall be made from resin conforming to the requirements of Type II materials as defined in ASTM specification D3307. The lining shall be made from virgin resin meeting the requirements of ASTM D3307 or clean reworked resin capable of meeting the requirements of this specification.

When tested in accordance with ASTM D3307, the minimum tensile strength shall be 26.2 N/mm² and the minimum elongation shall be 300 per cent.

The PFA shall have a maximum Melt flow rate of 2.5 g per 10 minutes when tested in accordance with ASTM D3307.

Pipe

Pipe shall be carbon steel to API 5L grade B, ASTM A106 grade B, ASTM A106 grade B or BS 3601/BS 3602 : part 1 equivalent.

Flanges and welding-neck collars shall be forged steel to ASTM A105.

Slip on welding collars shall be steel plate to BS1501-161-430A, DIN 17100 grade RSt 37-2 or NF A 35-501 grade E24.

Fittings

Fabricated fittings shall be manufactured from the materials stated above.

Cast fittings shall be manufactured from the following :

Ductile Iron – ASTM A395, BS2789 grade 420/12 or DIN 1693 Part 1 GGG40.

Cast steel – ASTM A216 WCB

Preface	Manufacturing Specification	Performance Data	Pipes and Fittings – ANSI	Pipes and Fittings – DIN	PTFE expansion bellows	
Sight Flow Indicator	Spectacle Blinds	Ball Check Valve	Level Indicator	Dip Pipes	Nozzle linings	Column Internals

#SURELINE

PIPE SYSTEMS

Fabrication standards

Qualification of welding procedures, welders and welding operators shall be in accordance with section IX of the ASME Boiler and Pressure Vessel Code or BS 4870 : Part 1 and BS 4871 : Part 1, DIN 8560 or EN-288-3.

All welds shall be visually examined and assessed in accordance with ASME B31.3 or relevant code.

Dimensional standards

Flanged cast steel fittings shall be in accordance with ANSI B16.5 Class 150.

Flanged Ductile Iron fittings shall be in accordance with ANSI B16.42 Class 150.

Fabricated fittings shall be in accordance with the dimensions shown in MB Plastics #Sureline manual.

Pipe diameters and wall thickness' shall be in accordance with the dimension table 1. below.

Flanges for pipe and fittings

Flanges for pipe and fittings shall be in accordance with ANSI B16.5 Class 150.

Flanges shall be slip on welding, socket welding or welding neck types.

Loose backing flanges shall be suitable for use with welding collars.

All relevant dimensions and tolerances shall be in accordance with ANSI B16.5 Class 150.

Threaded bolt holes are not permitted except for reducing flanges. Threaded bolt holes in reducing flanges shall be UNC unless specified otherwise.

Welding collars for use with loose backing flanges shall be slip on welding, socket welding or welding neck type.

The diameters and thickness' shall be as given in dimension table 1. below.

Spacers shall be either solid PTFE or lined steel. The outside diameters shall be as given in dimension table 1. below.

The outside diameter of instrument tee bodies shall be the same as lined spacers.

The minimum wall thickness of the linings shall be as given in dimension Table 1. The lining on the faces of flanges shall have uniform thickness and shall not be less than 80 per cent of the actual wall thickness.

The minimum lining face diameters shall be as given in dimension table 1.

Table 1

NB	Pipe OD	Pipe Sch	Pipe Thk	Collar OD +0 -2	Collar Thk	Spacer OD +0 -2	Min liner thk	Min face dia	Max Pipe length	Min Pipe length
1"	33.4	40	3.38	51	12	66.5	3.0	48	6000	140
1-1/2"	48.3	40	3.68	73	12	85.5	3.0	68	6000	150
2"	60.3	40	3.91	92	14	105.0	3.0	87	6000	150
3"	88.9	40	5.49	127	16	136.5	3.0	117	6000	170
4"	114.3	40	6.02	157	16	174.5	4.0	151	6000	180
6"	168.3	40	7.11	216	18	222.0	5.0	203	3000	205
8"	219.1	30	7.04	270	20	279.5	6.5	256	3000	225
10"	273.1	30	7.80	324	22	339.5	7.5	311	3000	235
12"	323.9	30	8.38	381	22	409.5	8.5	365	3000	255

Preface	Manufacturing Specification	Performance Data	Pipes and Fittings – ANSI	Pipes and Fittings – DIN	PTFE expansion bellows	
Sight Flow Indicator	Spectacle Blinds	Ball Check Valve	Level Indicator	Dip Pipes	Nozzle linings	Column Internals

#SURELINE

PIPE SYSTEMS

Construction

Pipe spools

Each flanged length shall have a fixed welded flange at one end and a welding collar with a loose backing flange at the other. Where vent bosses are not provided, a stop shall be provided on all spool lengths greater than 500mm. The stop is to prevent travel of the loose flange and shall be located within 150mm from the back of the collar. The stop shall be oriented so that it is on the centreline approximately opposite the vent hole.

Flanged fittings

Completed fittings shall be one piece construction. Flanges shall be fixed. The preparation and assembly of welded branch connections shall be in accordance with BS 2633 or ASME B31.3.

Attachment of flanges and collars.

The attachment of flanges and collars shall be by both back fillet and bore welds. The transition from the bore to the flanged face shall incorporate a radius to prevent undue stressing of the liner.

Fabrication dimensional tolerances.

Tolerances for flanges and fittings shall be in accordance with the relevant standards.

Fabricated pipework shall be in accordance with the following tolerances :

Straightness of pipes. No deviation of straightness greater than 1/500th of the length.

Squareness of flanges. Square to the axis of the pipe or fitting to within 0.05mm per 25mm measured across the face.

Flange faces. Faces shall not be uneven or concave. Convexity from the bore to the periphery shall not exceed 0.4mm per 25mm width of face.

Flange drilling. PCD +/- 1.5mm. c/c of bolt holes +/- 0.8mm. Eccentricity between PCD and RFD up to 2-1/2" +/- 0.8mm, 3" and greater +/- 1.5mm.

Bolt holes. Bolt holes shall be off centres and equally spaced about the centreline to an accuracy of 1.5mm.

Linear and angular dimensions. Linear dimensions +/- 1.5mm Angular dimensions +/- 0.25 Degrees.

Venting

Vent holes shall be provided in all pipe spools and fittings and shall be 3mm diameter.

Vent bosses

Where specified, each vent shall have a welding boss which shall be set on and welded using a full penetration weld as detailed in ICI specification EDS PIP 53 01 C. Vent bosses in pipe spools and PTFE or PFA lined fittings not having an injection boss shall be fitted with a PTFE vented plug. Fittings with injection bosses shall be fitted with a carbon steel vented plug.

Pipe lengths up to 500mm shall have one vent at mid point.

Lengths between 500mm and 6000mm shall have two vents, one at each end within approx 100mm of the back of the flange.

The vents shall be on the same longitudinal centre line which shall be opposite the flange stops where fitted.

Preface	Manufacturing Specification	Performance Data	Pipes and Fittings – ANSI	Pipes and Fittings – DIN	PTFE expansion bellows	
Sight Flow Indicator	Spectacle Blinds	Ball Check Valve	Level Indicator	Dip Pipes	Nozzle linings	Column Internals

#SURELINE

PIPE SYSTEMS

When specified, lengths above 4000mm shall have three vents, one at each end as above and an additional one at the mid point. The vents shall be on the same longitudinal centre line.

Internal finish of housings

The interior surfaces and flange faces shall be clean and free of sharp corners, burrs, rust, scale, weld spatter or other protrusions that could adversely affect the lining.

Lining

The method of lining and the fit of the lining shall ensure that the lining is capable of withstanding the temperature, pressure and vacuum ratings of the system.

All interference fit linings in straight pipes shall be normalised prior to flaring.

Completed linings shall show no evidence of pinholes, porosity, cracks or bad workmanship. Sealing surfaces shall be free of surface defects that could impair sealing effectiveness. Scratches, dents, nicks or tool marks on the sealing face shall not be deeper than 0.15mm. Any of these defect types less than 0.15mm but extending across the face shall cause the product to be rejected.

Blind flanges shall have linings firmly attached.

Production testing

PTFE tube tests

For each sinter batch, at least one representative sample of each nominal size of tube shall be selected and tests carried out to determine mechanical properties and SG.

Where samples do not comply with the requirements stated in this specification, each tube in the batch shall have samples cut from each end and the samples shall be subjected to the same tests. Any sample not meeting the specified requirements shall lead to rejection of the whole tube.

The outside diameter and wall thickness shall be measured. Tubes not complying with the standard shall be rejected.

Cracks found at the ends of tubes shall be cut off along with at least 50mm of adjacent material.

When specified, each liner tube shall be subjected to a flattening test. Each length of tube shall be passed through a pre-set gap between two powered rollers. The gap shall be set at 50 per cent of the outside diameter of the tube. The tube shall then be rotated about the longitudinal axis through 90 degrees and then passed back through the roller gap. The tube shall be examined for cracks and any cracks along with at least 50mm of adjacent material shall be cut out.

PFA Lining tests.

Regular production checks shall be carried out to determine mechanical properties and Melt flow rate of the material. Where the results do not comply with the requirements of this specification, the linings shall be rejected.

Preface	Manufacturing Specification	Performance Data	Pipes and Fittings – ANSI	Pipes and Fittings – DIN	PTFE expansion bellows	
Sight Flow Indicator	Spectacle Blinds	Ball Check Valve	Level Indicator	Dip Pipes	Nozzle linings	Column Internals

#SURELINE

PIPE SYSTEMS

Hydrostatic pressure test

All fittings and 10 per cent of pipe spools shall be subjected to a hydrostatic pressure test as follows:

The test shall be conducted at ambient temperature using clean water. The pipe or fitting shall be filled and the system bled free of all air. The test pressure of 26 Bar G shall be reached within 1 minute and maintained for at least 3 minutes. The pressure gauge and the venting holes / bosses in the pipe or fitting shall be observed throughout the test.

The pressure shall then be vented for not less than 30 seconds and a second test shall then be applied for a further period of not less than 3 minutes. Any evidence of leakage shall be cause for rejection.

Electrostatic test

Electrostatic testing shall be carried out at a minimum voltage of 20,000 V. The full surface of every lining shall be tested. Any pinholes shall be cause for rejection.

Final examination

Each item shall be examined visually. Following satisfactory completion, the outside edge of the flange shall be stamped with a letter “I” to indicate compliance.

External finish

The outside surface of all pipe and fittings shall be finished as follows.

Shotblast SA 2-1/2 and coat with one coat zinc phosphate or zinc silicate primer. After painting, bolt holes and vents which become blocked shall be cleared.

Marking and identification

The following information shall be marked permanently on each pipe and fitting either by casting into the body or by hard stamping the flange edge in letters at least 6mm high.

- A) Letter “M” to identify MB Plastics
- B) Letters “PT” to identify liner material

In the case of pipe spools, the length shall be indelibly marked on the pipe body.

Packaging

All flanges shall be fitted with protective covers. These covers shall only be removed just prior to installation.

Straight pipe spools shall be fitted with water resistant medium density fibreboard blanks using a minimum of 4 x M6 bolts. The bolts shall not protrude beyond the nut by more than 10mm.

Fittings shall be fitted with medium density fibreboard blanks as above or alternatively, snap on proprietary plastic blanks may be used.

Performance

All lined pipe and fittings shall be capable of meeting the temperature, pressure, and vacuum ratings stated in MB Plastics Ltd

#Sureline manual

Preface	Manufacturing Specification	Performance Data	Pipes and Fittings – ANSI	Pipes and Fittings – DIN	PTFE expansion bellows	
Sight Flow Indicator	Spectacle Blinds	Ball Check Valve	Level Indicator	Dip Pipes	Nozzle linings	Column Internals

#SURELINE

PIPE SYSTEMS

1.0 - Introduction

The Fluoropolymer Division of MB Plastics offers a comprehensive range of plastic lined pipe and fittings, under the designation #SURELINE, to two basic dimensional specifications and pressure ratings,

- **ANSI B16.5 class 150** with temperature limitations dependant upon the liner material., together with associated specific standards for lined products.
- **DIN 2848** – Flanged steel pipes and flanged steel or cast iron fittings PN 10.

These two basic dimensional products lines can be complemented on a project basis by specific products built to other specifications and pressure ratings.

These two standard product lines exist with a choice of three liner materials,

- **PTFE (Polytetrafluoroethylene) and PFA (Perfluoro-alkoxy)** destined to handle the most aggressive fluids.
- **PVDF (Polyvinylidene fluoride)** for a wide range of relatively aggressive chemicals.
- **PP (Polypropylene)** for applications not requiring the high levels of performance of the two previous lining materials.

The #SURELINE product range offers a choice of pipe systems capable of handling the most aggressive fluids, combining the chemical resistance of high performance thermoplastics and fluoropolymers with the mechanical strength of steel, one of the safest and long term effective corrosion resistant pipe systems available on the market today.

2.0 - Scope

This specification defines the general overall properties and performance, constituent materials, dimensions and configurations of the products available in the #SURELINE range of lined pipework, as well as describing basic guidelines for the design and installation. It should be read in conjunction with the specific product specifications referred to below.

3.0 - Product range and related detailed specifications.

The following materials are described in more detail in a range of different individual product specifications which are available upon request. The system comprises a full range of pipes and standard fittings as described below. The Fluoropolymer Division of MB Plastics can also supply custom manufactured items which may offer significant advantages in complex pipe systems. When the assembly of several fittings together causes problems due to overall dimensional restrictions, these fittings can in many instances be replaced by one more compact element.

3.1 - #SURELINE XT; the XT range of products relies upon two fluoropolymer materials, selected for their similar chemical and heat resistant properties as well as their specific manufacturing characteristics. As a basic rule, **PTFE** is used to line pipe and **PFA** is used to line fittings. Variations and exceptions exist, and further information is available on the following data sheets or from our technical services.

Preface	Manufacturing Specification	Performance Data	Pipes and Fittings – ANSI	Pipes and Fittings – DIN	PTFE expansion bellows	
Sight Flow Indicator	Spectacle Blinds	Ball Check Valve	Level Indicator	Dip Pipes	Nozzle linings	Column Internals

#SURELINE

PIPE SYSTEMS

3.2 - **#SURELINE XV**; uses **PVDF** as a lining material for both pipes and fittings.

3.3 - **#SURELINE XP**; uses **PP (Polypropylene)** for both pipe and fittings.

3.4 - Deviations from the referenced standards are permitted, in order to include substitution by BS, DIN and other national or international standards, where similar properties to those required by the ASTM standards are defined.

3.5 - The full range of fittings, whether manufactured by casting or fabrication, are all dimensioned to the relevant specification (ANSI B16.5 150# or 300# or DIN 2484). Housings dimensioned to ANSI 150# can also be supplied with flanges to BS 10 and BS 4504.

3.6 - Fabrication of spools is carried out generally to the requirements of ANSI B31.3, with the modifications required to suit lining processes and service constraints.

4.0 - Service limitations.

4.1 - For positive and negative pressure limitations versus temperature, see tables 1 and 2.

4.2 - Service temperature limits, subject to compatibility with the fluid being handled are;

- **#SURELINE XT** - minus 60° to +200°C

- **#SURELINE XV** - minus 20° to +120°C

- **#SURELINE XP** - minus 20° to +90°C

4.3 - When **#SURELINE XT** is exposed to very low temperatures (less than minus 20°C) consideration must be given as to the suitability of the material used for the housings. See section 5 below for further information.

4.4 - Chemical resistance.

#SURELINE XT can be regarded for all intents and purposes as being totally resistant to all chemical solutions except for;

- molten alkali metals and their solutions

- very strong fluorinating agents such as elemental fluorine and chlorine trifluoride.

The question of vapour permeation of PTFE can be important with some chemicals under certain operating conditions and this phenomena should be considered when selecting the lining material.

For further information on permeation, as well as on the chemical resistance of **#SURELINE XV** and **XP** systems, please contact our technical services department.

Preface	Manufacturing Specification	Performance Data	Pipes and Fittings – ANSI	Pipes and Fittings – DIN	PTFE expansion bellows	
Sight Flow Indicator	Spectacle Blinds	Ball Check Valve	Level Indicator	Dip Pipes	Nozzle linings	Column Internals

#SURELINE

PIPE SYSTEMS

5.0 - Materials of construction.

5.1 - Lining materials are specified as follow

5.1.1 - PTFE : The resins used meet the requirements of ASTM D4894-98a - Standard Specification for Polytetrafluoroethylene (PTFE) Granular Mouldings and Ram Extrusion Materials.

5.1.2 - PFA: The resins used meet the requirements of ASTM D3307-98 - Standard Specification for Perfluoro-alkoxy (PFA)-Fluorocarbon Resin Moulding and Extrusion Materials, type 11 (Higher molecular weight)

5.1.3 - PVDF: The resins used meet the requirements of ASTM D 3222 - 99 - Standard Specification for Unmodified Poly (Vinylidene Fluoride) (PVDF) Moulding Extrusion and Coating Materials. The resin is generally pigmented red in order to distinguish it from polypropylene.

5.1.4 - PP: The resins used meet the requirements of ASTM D4101 Standard Specification for Propylene Plastic Injection and Extrusion Materials, or equivalent. MB Plastics uses only copolymers, in order to guarantee the optimum combination of impact strength, heat and chemical resistance.

5.1.5 - PTFE and PFA linings are normally non-pigmented, whereas PVDF and PP may be pigmented, either for material identification or to facilitate a particular production process.

Anti static PTFE and PFA are modified versions of the specifications mentioned above, with volume resistivities less than 10⁶ ohm-cm, and are black in colour.

5.2 - Housing materials.

5.2.1 - Pipe spools are fabricated from carbon steel pipe to API 5l gr.B. Dimensions 25 through 200mm nominal bore are supplied in schedule 40, whereas 250 and 300mm nominal bore is supplied in schedule 30. Pipe to ASTM A 106-99el is also available upon request.

Stainless steel pipes are available in dimensions up to 300mm nominal bore, with wall thicknesses from schedule 5S to schedule 40.

5.2.2 - Flanges to ANSI B 16.5 in 150# and 300# are supplied in materials conforming to ASTM A 105/A105M-98 and flanges to DIN, BS 4504 and BS 10 are supplied in either the specified steel plate or forged steel materials.

5.2.3 - Fabricated and cast steel housings are available for low temperature applications

5.2.4 - Pipe fittings are available in the following materials and grades

- S.G. (Spheroidal Graphite) Iron to BS EN 1563:1997 (BS 2789) (standard and preferred by MB Plastics)
- Cast steel to ASTM A 216/A216M-93(1998)
- Welded steel fabrication using standard pipe, flanges and boiler plate as specific specifications may require.
- Stainless steel castings and fabrications are also available upon request.

Preface	Manufacturing Specification	Performance Data	Pipes and Fittings – ANSI	Pipes and Fittings – DIN	PTFE expansion bellows	
Sight Flow Indicator	Spectacle Blinds	Ball Check Valve	Level Indicator	Dip Pipes	Nozzle linings	Column Internals

#SURELINE

PIPE SYSTEMS

6.0 - Material Certification

6.1 - Housings are procured with supporting certification, normally to DIN 50049 3.1B, or with certificates of conformity endorsed by the manufacturer's own independent quality control department.

6.2 - Polymers are procured with the manufacturer's certificate of conformity.

7.0 - Fabrication procedures.

7.1 - Welding procedures for the attachment of flanges and for setting on of branches are available upon request.

8.0 - Painting systems.

8.1 - The MB Plastics standard specification requires that all external steel surfaces are shot blasted to SA 2.5/100 microns, followed by the application of a layer of zinc phosphate or zinc silicate primer. Final coatings and alternative finishes are available upon request.

9.0 - Identification.

9.1 - The liner specification is defined on the fixed flange of each pipe spool by hard stamping, such as PTFE/PP etc. This information is also painted on the body of the pipe or fitting, or on the flare cover of the fitting. More detailed identification to conform to a particular project or client specification can be supplied.

10.0 - Quality Management System

10.1 - MB Plastics is accredited to BS EN ISO 9001

11.0 - Specific Product Specifications (available upon request)

11.1 - MB004 Specification for PTFE & PFA lined pipe and fittings to ANSI 150

11.2 - MB006 Specification for PTFE & PFA lined pipe and fittings to DIN 2848

11.3 - MB007 Specification for PVDF lined pipe and fittings to ANSI 150

11.4 - MB008 Specification for PVDF lined pipe and fittings to DIN 2848

11.5 - MB005 Specification for PP lined pipe and fittings to ANSI 150

11.6 - MB009 Specification for PP lined pipe and fittings to DIN 2848

Preface	Manufacturing Specification	Performance Data	Pipes and Fittings – ANSI	Pipes and Fittings – DIN	PTFE expansion bellows	
Sight Flow Indicator	Spectacle Blinds	Ball Check Valve	Level Indicator	Dip Pipes	Nozzle linings	Column Internals

#SURELINE

PIPE SYSTEMS

Tables

Pressure / temperature ratings

Temperature °C	Pressure			
	Series ANSI 150#		Series ANSI 300#	
	psi	bar	psi	bar
20	250	17.2	450	31.0
50	244	17.0	425	29.3
100	235	16.0	390	26.9
150	215	14.8	345	23.8
200	200	13.9	295	20.3

Table 1 - valid for series XT (PTFE-PFA) up to 200°C / XV (PVDF) up to 120°C and XP (Polypropylene) up to 90°C.

The pressure ratings for ANSI 150# and PN16 dimensioned fittings are based on ratings in ANSI B 16.5.

The pressure ratings for ANSI 300# dimensioned fittings are based on the rating in ANSI B 16.5 300#, down rated to compensate for the decrease in mechanical properties at elevated temperatures of the lining materials.

Full vacuum / temperature ratings

Specification	Temperature °C	Diameter (mm)								
		25	40	50	80	100	150	200	250	300
XT (PTFE-PFA)	20	full	full	full	full	full	full	full	full	full
	100	full	full	full	full	full	full	full	full	
	150	full	full	full	full	full	full	full		
	200	full	full	full	full	full	full			
XV (PVDF)	20	full	full	full	full	full	full	full	full	full
	80	full	full	full	full	full				
	120	full	full	full	full	full				
XP (PP)	20	full	full	full	full	full	full	full	full	full
	90	full	full	full	full	full	full	full	full	full

Table 2

Limitation of vacuum service is determined by methods which comply with the relevant ASTM testing methods for lined pipe.

Preface	Manufacturing Specification	Performance Data	Pipes and Fittings – ANSI	Pipes and Fittings – DIN	PTFE expansion bellows	
Sight Flow Indicator	Spectacle Blinds	Ball Check Valve	Level Indicator	Dip Pipes	Nozzle linings	Column Internals

#SURELINE

PIPE SYSTEMS

12.0 - System design and supports.

12.1 - Due to the nature of the dual system of a metallic structure and a thermoplastic inner liner, the potential risk of leakage is situated at flange assemblies, especially if the system is installed without gaskets. The risk of leakage due to difficulties in assembly without gaskets is covered in the following section. Flanges may also leak because of high stress levels imposed on flanges due either to poor installation, lack of supports or non containment of forces and movements due to thermal expansion.

12.2 - Whilst it may not be necessary to run a stress analysis on every system, the designer should make every effort to avoid undue stress and movement due to thermal expansion, either by incorporating directional changes or expansion bellows. Stress analysis of systems working at high temperature is recommended.

12.3 - Pipe systems should be adequately supported in order to avoid excessive deflection of flanged joints, and supports should be installed preferably close to flanges. The requirement for adequate support is critical in areas of high levels of concentration of valves and fittings.

12.4 - Butterfly valves are usually designed for straight metallic or thermoplastic systems, with the diameter of the vane being defined as a function of the inner diameter of the pipe system in question. The inner diameter of lined steel pipe is considerably smaller than the actual steel pipe, and inner diameters of thermoplastic pipes tend to be considerably smaller due to their heavy wall thickness. For these reasons some interference between the inner liner of a lined pipe and the valve vane may be experienced. The designer should consider this possibility early in the selection process for pipe systems and valves, and if required, incorporate adequate conical spacers between the flanges of plastic lined pipe or fittings and the valve.

13 - Installation and maintenance instructions for #Sureline lined pipes, fittings & expansion joints

13.01 - Lined products must not be welded, brazed or torch cut since this will damage the lining. The material should also be handled with due care and attention, avoiding all mechanical shocks.

13.02 - All flanges are covered to protect them from damage during shipment, storage and handling on site. Should covers be removed for inspection purposes prior to installation, they should be replaced immediately after the inspection of each item is completed. Under normal conditions, covers should only be removed immediately prior to installation. As gaskets are often not required (see below), utmost attention should be made to avoid scratching or otherwise damaging the lining on flange faces.

13.03 - When jointing PTFE/PFA lined pipe and / or fittings together it is generally unnecessary to use gaskets between the sealing faces. On the other hand, when connecting to other materials (steel, thermoplastics, glass fibre reinforced plastic etc) gaskets are mandatory. Gaskets are also required, on both sides, when solid spacers are used. Gaskets may also be used where flange faces are not absolutely parallel or where a gasket will act as a very thin spacer. When pipework is dismantled and then re-assembled it may be necessary to install gaskets prior to re-assembly.

Preface	Manufacturing Specification	Performance Data	Pipes and Fittings – ANSI	Pipes and Fittings – DIN	PTFE expansion bellows	
Sight Flow Indicator	Spectacle Blinds	Ball Check Valve	Level Indicator	Dip Pipes	Nozzle linings	Column Internals

#SURELINE

PIPE SYSTEMS

13.04 - When joining PVDF or PP lined pipe systems MB Plastics recommend that gaskets should be used, although with correct installation it is possible to obtain perfect sealing without them. Torque ratings to achieve sealing of PVDF and PP lined systems without the use of gaskets are relatively high (see below), and lined flange faces may be deformed to the extent that should pipework be dismantled for servicing, the deformation may inhibit subsequent sealing when the pipework is re-assembled. A gasket may be used at this stage in order to obtain sealing, but in the case that several contiguous fittings have been dismantled, the subsequent introduction of gaskets may cause overall dimensional problems. The operator should also pay attention to modify torque ratings for the assembly of joints subsequently using a gasket.

Replacement of existing gaskets on an installation which has used gaskets as from the original assembly is, in many cases where PVDF or PP is concerned, a more economic and practical solution.

13.05 - As mentioned above, relatively high torque values are required to obtain sealing without gaskets, but excessive torque can deform the flange face to the extent that a gasket

will be required. To avoid this situation as much as possible, the following torque ratings are recommended for jointing lined pipe and fittings for operations at maximum operating temperatures.

Note that for pipe systems working at ambient temperature these torque ratings may be increased by 50%, in increments of 10%, should any initial leakage occur.

If a flanged connection assembled without a gasket starts to leak even though all the bolts have been tightened to the maximum torque rating, DO NOT CONTINUE TO TIGHTEN THEM ANY MORE. Instead, loosen slightly the bolts opposite the leak, and then tighten up the bolts in the area of the leakage. If leakage persists, the sealing faces of both components should be inspected for grooves or chips. Grooves or nicks not deeper than approximately 15% of the flare thickness can be removed with a fine grade abrasive paper.

13.06 - Note also that for bolting up joints with a gasket, or when bolting up to vessels or non-lined in line equipment, the operator should **respect the torque rating specified for the gasket or for the other equipment or material**, as this will generally be significantly lower than the rating required for lined pipe.

13.07 - Installation instructions specific to pipe systems without gaskets.

13.07.1 - All bolts should be tightened using a torque wrench, gradually tightening opposite bolts in order to ensure uniform stress, increasing torque by approximately 20% of the required torque in 5 sequential operations. All joints should be re-torqued after an initial period of at least 24 hours and/or after an initial thermal cycle which has taken the system to the defined service temperature.

13.07.2 - The following torque ratings are established for 3 different lining materials, for ANSI Class 150 systems, using A193 B7 bolts and A194 2H nuts as a minimum requirement for the determination of minimum mechanical properties.

Please contact our technical services for torque ratings to be applied for higher pressure ratings.

Preface	Manufacturing Specification	Performance Data	Pipes and Fittings – ANSI	Pipes and Fittings – DIN	PTFE expansion bellows	
Sight Flow Indicator	Spectacle Blinds	Ball Check Valve	Level Indicator	Dip Pipes	Nozzle linings	Column Internals

#SURELINE

PIPE SYSTEMS

Bolt dimensions and torque ratings

Nominal pipe size (mm)	N° and diameter of bolts	Bolt torque XP		Bolt torque XV		Bolt torque XT	
		(ft/lb.)	(Nm)	(ft/lb.)	(Nm)	(ft/lb.)	(Nm)
25	4 x 12	12	17	15	21	8	11
40	4 x 12	30	41	40	55	20	28
50	4 x 12	60	83	80	110	40	55
65	4 x 16	80	110	100	138	50	69
80	4 x 16	100	138	130	179	60	83
100	8 x 16	65	90	90	124	40	55
125	8 x 20	90	124	120	166	65	90
150	8 x 20	110	152	160	221	75	104
200	8 x 20	140	193	210	290	100	138
250	12 x 22	140	193	200	276	90	124
300	12 x 22	170	235	250	345	120	166

Table 3 - Bolt dimensions and torque ratings for assembly of flanges without gaskets.

13.08 - Please note that all threads should be clean and lightly lubricated, and that the use of standard washers under both bolt head and nut is strongly recommended.

13.09 - In order to avoid causing damage to the sealing faces, flanges on pipes and fittings working at temperatures above 40°C should only be dismantled once the temperature of the system has been reduced to this temperature level.

13.10 - All PTFE/PFA lined products have small vent holes in the steel housing. It is important that these holes are not blocked by insulation or plugged by paint, as this may cause the lining to collapse.

Preface	Manufacturing Specification	Performance Data	Pipes and Fittings – ANSI	Pipes and Fittings – DIN	PTFE expansion bellows	
Sight Flow Indicator	Spectacle Blinds	Ball Check Valve	Level Indicator	Dip Pipes	Nozzle linings	Column Internals

#SURELINE

PIPE SYSTEMS

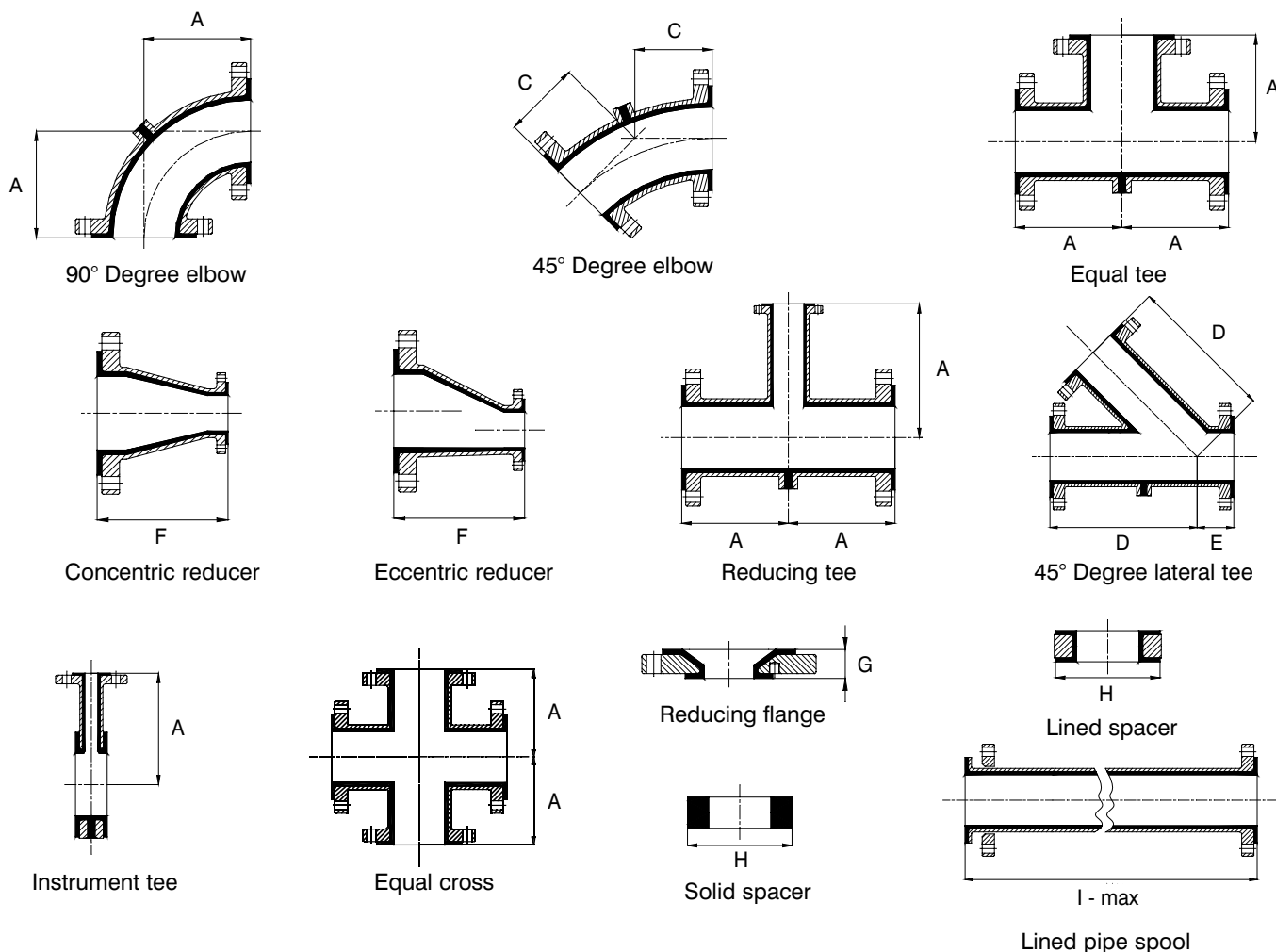

NB		A	C	D	E	F	G	H	I-max	I-max	I-min	I - min
									PTFE	PVDF/PP	PTFE	PVDF/PP
inch	mm	mm	mm	mm	mm	mm	mm	mm	mm	mm	mm	mm
1/2	15	65	45	*	*	*	*	*	1000	N/A	140	N/A
3/4	20	75	45	*	*	*	*	*	1000	N/A	140	N/A
1	25	89	45	146	45	114	35	66	6000	6000	140	140
1 1/2	40	102	57	178	51	114	35	85	6000	6000	150	150
2	50	114	64	203	64	127	35	105	6000	6000	150	150
3	80	140	76	254	76	152	35	136	6000	6000	170	170
4	100	165	102	305	76	178	45	174	6000	6000	180	180
6	150	203	127	368	89	229	45	222	6000	6000	205	205
8	200	229	140	445	114	279	45	279	3000	6000	225	225
10	250	279	165	521	127	305	45	339	3000	3000	235	235
12	300	305	191	622	140	356	45	409	3000	3000	255	255

* information available upon request N/A - not available

Preface	Manufacturing Specification	Performance Data	Pipes and Fittings – ANSI	Pipes and Fittings – DIN	PTFE expansion bellows	
Sight Flow Indicator	Spectacle Blinds	Ball Check Valve	Level Indicator	Dip Pipes	Nozzle linings	Column Internals

#SURELINE

PIPE SYSTEMS

PIPE SPOOL – PVDF & PP

ANSI # 150

Housing - fabricated carbon steel

Pipe : API 5L Gr. B

Flange : ASTM A105/A105 M-98

Collar : BS EN10273:2000 (BS1501:1982)

Liner-PTFE

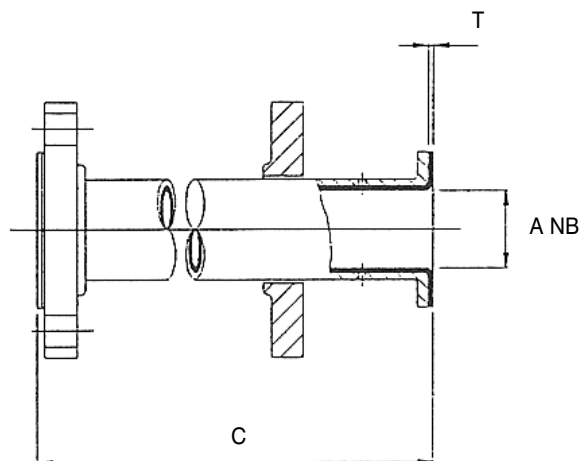

A		C max	C mini	T (mm)*	Approx. Weight	
inch	mm	mm	mm	mm	1m ~ kg	+1m ~ kg
1/2	15	1000	140	2.00	2.0	1.5
3/4	20	1000	140	2.00	3.0	2.1
1	25	6000	140	3.18	5.2	3.1
1 1/2	40	6000	150	3.18	7.5	5.0
2	50	6000	150	3.18	10.8	6.6
3	80	6000	170	3.18	20.0	12.9
4	100	6000	180	4.25	29.8	18.6
6	150	6000	205	5.25	48.7	33.8
8	200	3000	225	6.75	75.5	52.0
10	250	3000	235	7.75	98.4	62.0
12	300	3000	255	8.75	120.1	82.0

* T - liner thickness is indicative and may vary slightly from batch to batch
Actual dimensions and tolerances for specific orders are available upon request.

Preface	Manufacturing Specification	Performance Data	Pipes and Fittings – ANSI	Pipes and Fittings – DIN	PTFE expansion bellows	
Sight Flow Indicator	Spectacle Blinds	Ball Check Valve	Level Indicator	Dip Pipes	Nozzle linings	Column Internals

#SURELINE

PIPE SYSTEMS

PIPE SPOOL – PVDF & PP

ANSI # 150

Housing - fabricated carbon steel

Pipe : API 5L Gr. B

Flange : ASTM A105/A105 M-98

Collar : BS EN10273:2000 (BS1501:1982)

Liner - PVDF & PP

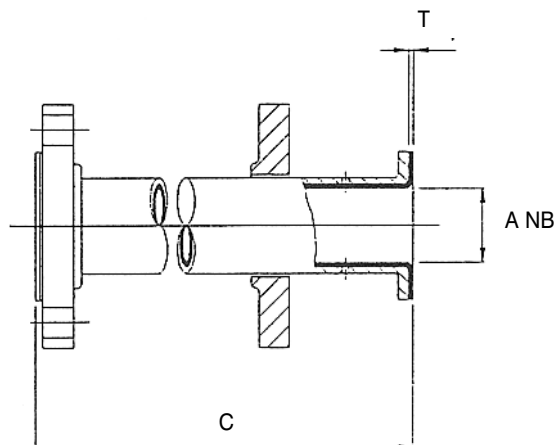

A		C max mm	C mini mm	T (mm)*		Approx. Weight	
inch	mm			PVDF	PP	1m Z ~ kg	+1m ~ kg
1	25	6000	140	2.54	3.81	5.2	3.1
1½	40	6000	150	2.54	4.06	7.5	5.0
2	50	6000	150	2.54	4.45	10.8	6.6
3	80	6000	170	2.54	4.45	20.0	12.9
4	100	6000	180	2.54	5.33	29.8	18.6
6	150	6000	205	3.68	5.60	48.7	33.8
8	200	6000	225	4.06	5.60	75.5	52.0
10	250	6000	235	5.60	6.35	98.4	62.0
12	300	6000	255	6.35	6.35	120.1	82.0

.....

* T - liner thickness is indicative and may vary slightly from batch to batch
Actual dimensions and tolerances for specific orders are available upon request.

#SURELINE

PIPE SYSTEMS

PIPE SPOOL - JACKETED

ANSI # 150

Housing - fabricated carbon steel

Pipe : API 5L Gr. B

Flange : ASTM A105/A105 M-98

Collar : BS EN10273:2000 (BS1501:1982)

Liner - PTFE

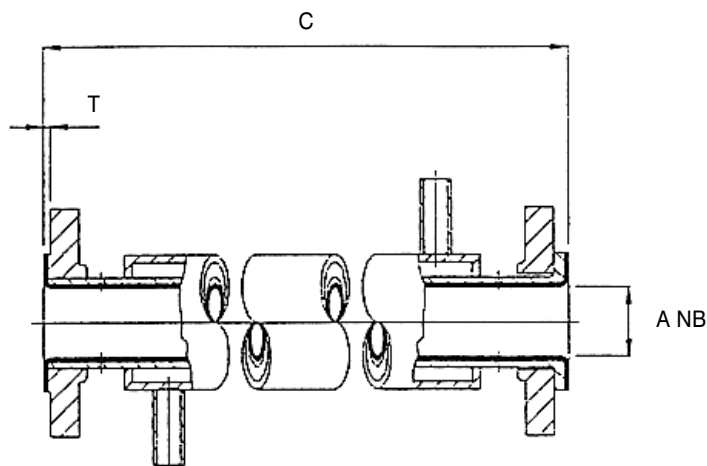

A		C max	C mini	T (mm)*	Approx. Weight	
inch	mm	mm	mm	mm	1m ~ kg	+1m ~ kg
1	25	6000	140	3.18	10	7
1½	40	6000	150	3.18	14	10
2	50	6000	150	3.18	23	18
3	80	6000	170	3.18	37	29
4	100	6000	180	4.25	59	47
6	150	6000	205	5.25	87	71
8	200	3000	225	6.75	127	103
10	250	3000	235	7.75	166	128
12	300	3000	255	8.75	203	164

Jackets for pipe diameter 1" through 4" are supplied in schedule 40, whereas diameter 6" through 12" are supplied in schedule 30.

* T - liner thickness is indicative and may vary slightly from batch to batch.

Actual dimensions and tolerances for specific orders are available upon request.

Preface	Manufacturing Specification	Performance Data	Pipes and Fittings – ANSI	Pipes and Fittings – DIN	PTFE expansion bellows
Sight Flow Indicator	Spectacle Blinds	Ball Check Valve	Level Indicator	Dip Pipes	Nozzle linings
					Column Internals

#SURELINE

PIPE SYSTEMS

90° ELBOW

ANSI # 150

Housing

S.G. Iron - BS EN 1563:1997 (BS2789:1985)

Cast steel - ASTM A216/A216M-93 (1998)

Liner - PFA / PVDF / PP

PTFE lined elbows are available within fabricated carbon steel housings.

Liner thickness and overall weight may vary from information below.

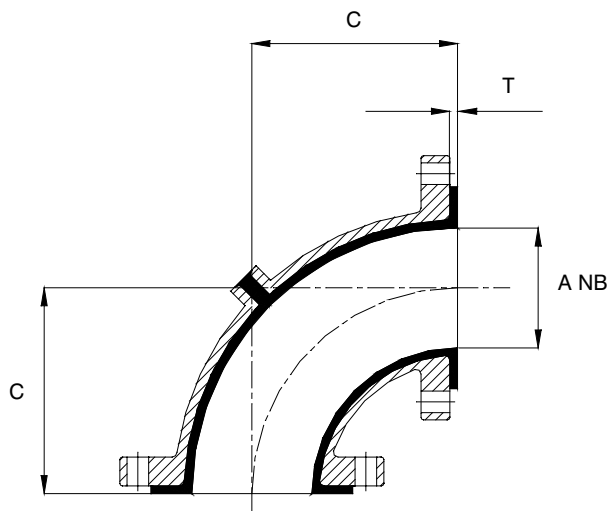

A		C	T *	Approx. Weight
inch	mm	mm	mm	~ kg
1/2	15	65	1.5	1.9
3/4	20	75	1.5	2.0
1	25	89	5.6	2.4
1 1/2	40	102	5.6	3.9
2	50	114	5.6	6.4
3	80	140	5.6	12
4	100	165	6.4	19
6	150	203	7.1	34
8	200	229	7.9	57
10	250	279	7.9	91
12	300	305	9.5	110

* T - liner thickness is indicative and may vary slightly from batch to batch
Actual dimensions and tolerances for specific orders are available upon request.

Preface	Manufacturing Specification	Performance Data	Pipes and Fittings – ANSI	Pipes and Fittings – DIN	PTFE expansion bellows	
Sight Flow Indicator	Spectacle Blinds	Ball Check Valve	Level Indicator	Dip Pipes	Nozzle linings	Column Internals

#SURELINE

PIPE SYSTEMS

45° ELBOW

ANSI # 150

Housing

S.G. Iron - BS EN 1563:1997 (BS2789:1985)

Cast steel - ASTM A216/A216M-93 (1998)

Liner - PFA / PVDF / PP

PTFE lined elbows are available within fabricated carbon steel housings.

Liner thickness and overall weight may vary from information below.

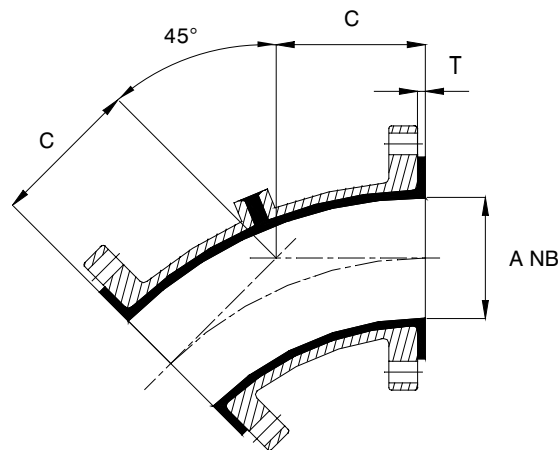

A		C	T *	Approx. Weight
inch	mm	mm	mm	~ kg
1/2	15	45	1.5	1.7
3/4	20	45	1.5	1.9
1	25	45	5.6	2.0
1 1/2	40	57	5.6	3.2
2	50	64	5.6	4.8
3	80	76	5.6	9.8
4	100	102	6.4	17
6	150	127	7.1	29
8	200	140	7.9	50
10	250	165	7.9	73
12	300	190	9.5	87

* T - liner thickness is indicative and may vary slightly from batch to batch
Actual dimensions and tolerances for specific orders are available upon request.

Preface	Manufacturing Specification	Performance Data	Pipes and Fittings – ANSI	Pipes and Fittings – DIN	PTFE expansion bellows	
Sight Flow Indicator	Spectacle Blinds	Ball Check Valve	Level Indicator	Dip Pipes	Nozzle linings	Column Internals

#SURELINE

PIPE SYSTEMS

EQUAL TEE

ANSI # 150

Housing

SG.Iron-BS EN 1563:1997(BS2789:1985)

Cast steel-ASTM A216/A216M-93 (1998)

Fabricated carbon steel

Liner - PFA / PVDF / PP

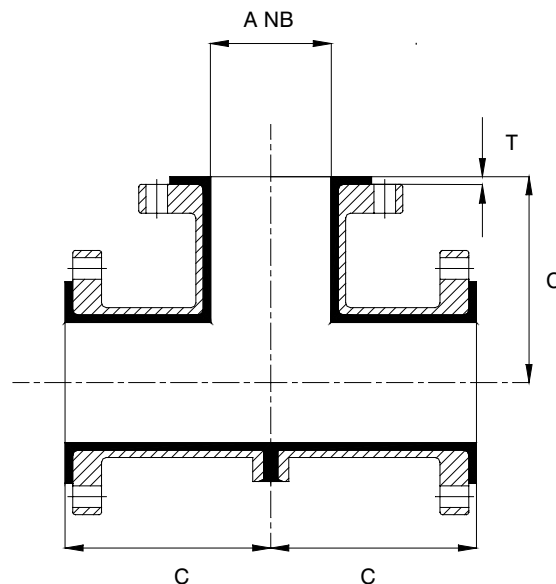

A		C	T *	Approx. Weight
inch	mm	mm	mm	~ kg
1/2	15	65	2.9	2.0
3/4	20	75	2.9	2.8
1	25	89	5.6	4.5
1 1/2	40	102	5.6	6.4
2	50	114	5.6	8.9
3	80	140	5.6	18
4	100	165	6.4	30
6	150	203	7.1	55
8	200	229	7.9	82
10	250	279	7.9	132
12	300	305	9.5	181

* T - liner thickness is indicative and may vary slightly from batch to batch
Actual dimensions and tolerances for specific orders are available upon request.

#SURELINE

PIPE SYSTEMS

REDUCED TEE

ANSI # 150

Housing

SG.Iron-BS EN 1563:1997(BS2789:1985)

Cast steel-ASTM A216/A216M-93 (1998)

Fabricated carbon steel

Liner - PFA / PVDF / PP

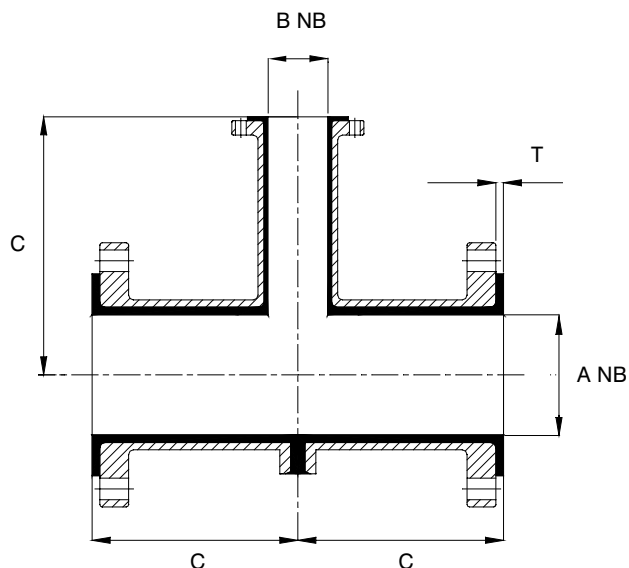

A		B		C	T*	Weight	A		B		C	T*	Weight
inch	mm	inch	mm	mm	mm	kg	inch	mm	inch	mm	mm	mm	kg
1	25	1/2	15	89	5.6	4.0	6	150	1	25	203	7.1	40
1	25	3/4	20	89	5.6	4.5	6	150	1 1/2	40	203	7.1	44
1 1/2	40	1/2	15	102	5.6	6.0	6	150	2	50	203	7.1	47
1 1/2	40	3/4	20	102	5.6	6.5	6	150	3	80	203	7.1	50
1 1/2	40	1	25	102	5.6	6.5	6	150	4	100	203	7.1	53
2	50	3/4	20	114	5.6	7.0	8	200	1	25	229	7.9	68
2	50	1	25	114	5.6	8.0	8	200	1 1/2	40	229	7.9	70
2	50	1 1/2	40	114	5.6	9.0	8	200	2	50	229	7.9	72
3	80	1	25	140	5.6	14	8	200	3	80	229	7.9	74
3	80	1 1/2	40	140	5.6	15	8	200	4	100	229	7.9	77
3	80	2	50	140	5.6	16	8	200	6	150	229	7.9	79
4	100	1	25	165	6.4	23	10	250	6	150	279	7.9	114
4	100	1 1/2	40	165	6.4	25	10	250	8	200	279	7.9	120
4	100	2	50	165	6.4	27	12	300	6	150	306	9.5	155
4	100	3	80	165	6.4	29	12	300	8	200	306	9.5	165
							12	300	10	250	306	9.5	174

* T - liner thickness is indicative and may vary slightly from batch to batch

Actual dimensions and tolerances for specific orders are available upon request.

Preface	Manufacturing Specification	Performance Data	Pipes and Fittings – ANSI	Pipes and Fittings – DIN	PTFE expansion bellows	
Sight Flow Indicator	Spectacle Blinds	Ball Check Valve	Level Indicator	Dip Pipes	Nozzle linings	Column Internals

#SURELINE

PIPE SYSTEMS

CONCENTRIC REDUCER

ANSI # 150

Housing

SG.Iron-BS EN 1563:1997(BS2789:1985)

Cast steel-ASTM A216/A216M-93 (1998)

Fabricated carbon steel

Liner - PFA / PVDF / PP

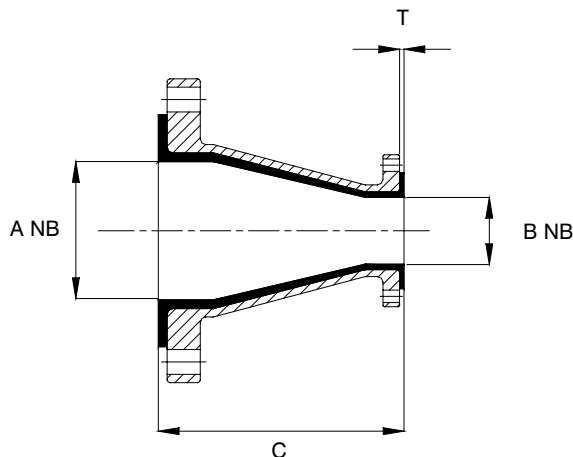

A		B		C	T*	Weight	A		B		C	T*	Weight
inch	mm	inch	mm	mm	mm	kg	inch	mm	inch	mm	mm	mm	kg
1	25	1/2	15	114	3.0	2	6	150	1	25	229	7.1	18
1	25	3/4	20	114	3.0	2	6	150	1 1/2	40	229	7.1	19
1 1/2	40	1/2	15	114	5.6	3	6	150	3	80	229	7.1	20
1 1/2	40	3/4	20	114	5.6	3	6	150	4	100	229	7.1	24
1 1/2	40	1	25	114	5.6	3	8	200	4	100	279	7.9	24
2	50	1	25	127	5.6	4	8	200	6	150	279	7.9	35
2	50	1 1/2	40	127	5.6	5	10	250	4	100	305	7.9	48
3	80	1	25	152	5.6	6	10	250	6	150	305	7.9	48
3	80	1 1/2	40	152	5.6	7	10	250	8	200	305	7.9	57
3	80	2	50	152	5.6	8	12	300	8	200	356	9.5	77
3	80	2 1/2	65	152	5.6	9	12	300	10	250	356	9.5	86
4	100	1	25	178	6.4	10							
4	100	1 1/2	40	178	6.4	10							
4	100	2	50	178	6.4	11							
4	100	2 1/2	65	178	6.4	12							
4	100	3	80	178	6.4	13							

* T - liner thickness is indicative and may vary slightly from batch to batch

Actual dimensions and tolerances for specific orders are available upon request.

MB Plastics reserves the right, dependant upon product availability, delivery schedules etc, to supply reducers as a composite fitting composed of a reducer and a reducing flange(s).

Preface	Manufacturing Specification	Performance Data	Pipes and Fittings – ANSI	Pipes and Fittings – DIN	PTFE expansion bellows	
Sight Flow Indicator	Spectacle Blinds	Ball Check Valve	Level Indicator	Dip Pipes	Nozzle linings	Column Internals

#SURELINE

PIPE SYSTEMS

ECCENTRIC REDUCER

ANSI # 150

Housing

Cast steel–ASTM A216/A216M-93(1998)

Fabricated carbon steel

Liner - PTFE / PFA / PVDF / PP

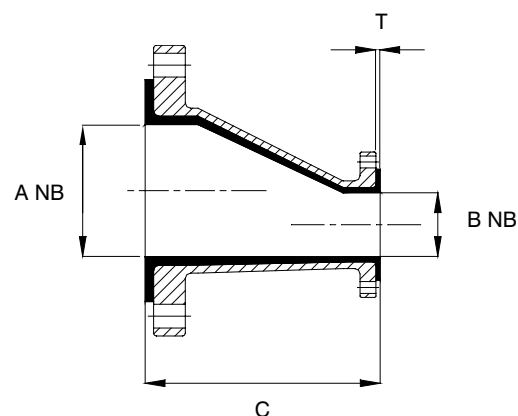

A		B		C	T*	Weight	A		B		C	T*	Weight
inch	mm	inch	mm	mm	mm	kg	inch	mm	inch	mm	mm	mm	kg
1	25	1/2	15	114	3.0	2	6	150	1	25	229	7.1	18
1	25	3/4	20	114	3.0	2	6	150	1 1/2	40	229	7.1	19
1 1/2	40	1/2	15	114	5.6	3	6	150	3	80	229	7.1	20
1 1/2	40	3/4	20	114	5.6	3	6	150	4	100	229	7.1	24
1 1/2	40	1	25	114	5.6	3	8	200	4	100	279	7.9	24
2	50	1	25	127	5.6	4	8	200	6	150	279	7.9	35
2	50	1 1/2	40	127	5.6	5	10	250	4	100	305	7.9	48
3	80	1	25	152	5.6	6	10	250	6	150	305	7.9	48
3	80	1 1/2	40	152	5.6	7	10	250	8	200	305	7.9	57
3	80	2	50	152	5.6	8	12	300	8	200	356	9.5	77
3	80	2 1/2	65	152	5.6	9	12	300	10	250	356	9.5	86
4	100	1	25	178	6.4	10							
4	100	1 1/2	40	178	6.4	10							
4	100	2	50	178	6.4	11							
4	100	2 1/2	65	178	6.4	12							
4	100	3	80	178	6.4	13							

* T - liner thickness is indicative and may vary slightly from batch to batch

Actual dimensions and tolerances for specific orders are available upon request.

MB Plastics reserves the right, dependant upon product availability, delivery schedules etc, to supply reducers as a composite fitting composed of a reducer and a reducing flange(s).

Preface	Manufacturing Specification	Performance Data	Pipes and Fittings – ANSI	Pipes and Fittings – DIN	PTFE expansion bellows	
Sight Flow Indicator	Spectacle Blinds	Ball Check Valve	Level Indicator	Dip Pipes	Nozzle linings	Column Internals

#SURELINE

PIPE SYSTEMS

INSTRUMENT TEE

ANSI # 150

Housing

SG. Iron - BS EN 1563:1997 (BS2789:1985)

Fabricated carbon steel –

Body plate : BS EN 10273:2000 (BS1501)

Flange : ASTM A105/A105M-98

Liner : PFA

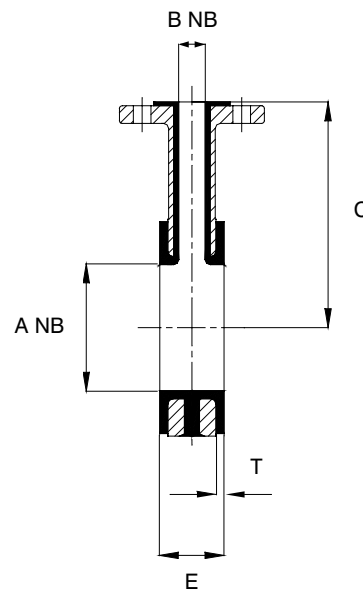

B			3/4"-20mm		1"-25mm		1 1/4"-32mm		1 1/2"-40mm		2"-50mm		
A	C	T	E	~kg	E	~kg	E	~kg	E	~kg	E	~kg	
inch	mm	mm	mm	mm	mm	mm	mm	mm	mm	mm	mm	mm	
1	25	89	5.6	51	4.5	51	4.7	n/a	n/a	n/a	n/a	n/a	n/a
1 1/4	32	102	5.6	51	5.1	51	5.3	76	6.9	n/a	n/a	n/a	n/a
1 1/2	40	102	5.6	51	5.7	51	5.9	76	8.3	76	8.5	n/a	n/a
2	50	114	5.6	51	7.0	51	7.2	76	11	76	n/a	n/a	n/a
2 1/2	65	160	5.6	51	8.7	51	9	76	14	76	14	89	19
3	80	160	5.6	51	10	51	10	76	16	76	16	89	19
4**	100**	179	6.4	51	14	51	14	76	23	76	23	89	26
5	125	205	6.4	51	16	51	16	76	29	76	29	89	30
6	150	205	7.1	51	18	51	18	76	35	76	35	89	33
8	200	237	7.9	51	26	51	27	76	41	76	41	89	45
10	250	264	7.9	51	33	51	33	76	53	76	53	89	59
12	300	318	7.9	51	46	51	47	76	82	76	82	89	82

** Hole patterns on 4" flanges require threaded bolt holes on 2" / 50mm branch items

* T - liner thickness is indicative and may vary slightly from batch to batch

Actual dimensions and tolerances for specific orders are available upon request.

Preface	Manufacturing Specification	Performance Data	Pipes and Fittings – ANSI	Pipes and Fittings – DIN	PTFE expansion bellows	
Sight Flow Indicator	Spectacle Blinds	Ball Check Valve	Level Indicator	Dip Pipes	Nozzle linings	Column Internals

#SURELINE

PIPE SYSTEMS

INSTRUMENT TEE

ANSI # 150

Housing

Fabricated carbon steel –

Body plate : BS EN 10273:2000 (BS1501)

Flange : ASTM A105/A105M-98

Liner : PVDF & PP

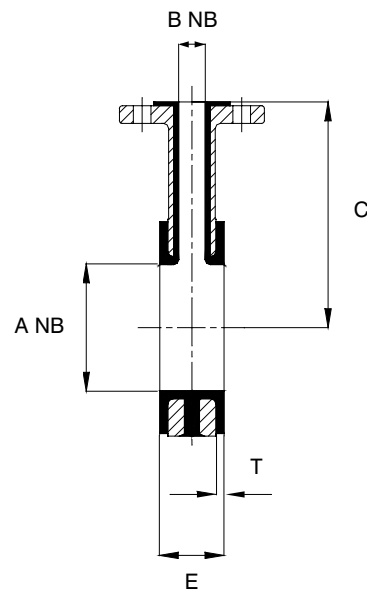

B			3/4" - 20mm		1" - 25mm		1 1/4" - 32mm		1 1/2" - 40mm		2" - 50mm		
A	C	T	E	~kg	E	~kg	E	~kg	E	~kg	E	~kg	
inch	mm	mm	mm		mm		mm		mm		mm		
1	25	89	5.6	51	4.5	51	4.7	n/a	n/a	n/a	n/a	n/a	n/a
1 1/4	32	102	5.6	51	5.1	51	5.3	76	6.9	n/a	n/a	n/a	n/a
1 1/2	40	102	5.6	51	5.7	51	5.9	76	8.3	76	8.5	n/a	n/a
2	50	114	5.6	51	7.0	51	7.2	76	11	76	n/a	n/a	n/a
2 1/2	65	160	5.6	51	8.7	51	9	76	14	76	14	89	19
3	80	160	5.6	51	10	51	10	76	16	76	16	89	19
4**	100**	179	6.4	51	14	51	14	76	23	76	23	89	26
5	125	205	6.4	51	16	51	16	76	29	76	29	89	30
6	150	205	7.1	51	18	51	18	76	35	76	35	89	33
8	200	237	7.9	51	26	51	27	76	41	76	41	89	45
10	250	264	7.9	51	33	51	33	76	53	76	53	89	59
12	300	318	7.9	51	46	51	47	76	82	76	82	89	82

** Hole patterns on 4" flanges require threaded bolt holes on 2" / 50mm branch items

* T - liner thickness is indicative and may vary slightly from batch to batch

Actual dimensions and tolerances for specific orders are available upon request.

Preface	Manufacturing Specification	Performance Data	Pipes and Fittings – ANSI	Pipes and Fittings – DIN	PTFE expansion bellows	
Sight Flow Indicator	Spectacle Blinds	Ball Check Valve	Level Indicator	Dip Pipes	Nozzle linings	Column Internals

#SURELINE

PIPE SYSTEMS

EQUAL CROSS

ANSI # 150

Housing

S.G. Iron - BS EN 1563:1997 (BS2789:1985)

Cast steel - ASTM A216/A216M-93 (1998)

Fabricated carbon steel.

Liner - PFA / PVDF / PP

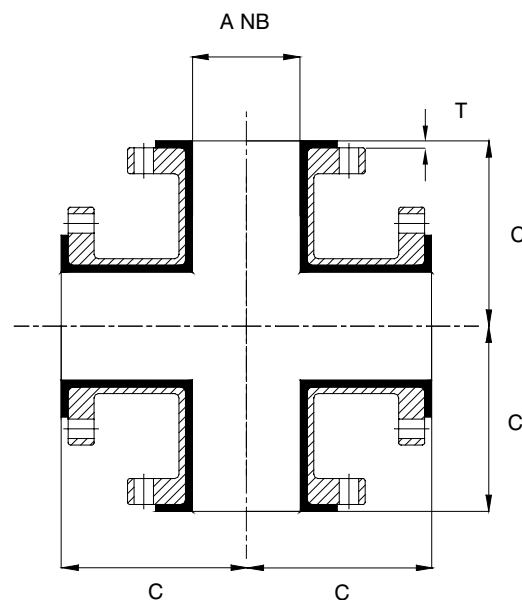

A		C	T *	Approx. Weight
inch	mm	mm	mm	~ kg
1/2	15	65	2.9	3.1
3/4	20	75	2.9	3.9
1	25	89	5.6	5.4
1 1/2	40	102	5.6	8.6
2	50	114	5.6	13
3	80	140	5.6	23
4	100	165	6.4	39
6	150	203	7.1	66
8	200	229	7.9	99
10	250	279	7.9	161

* T - liner thickness is indicative and may vary slightly from batch to batch
Actual dimensions and tolerances for specific orders are available upon request.

#SURELINE

PIPE SYSTEMS

LATERAL TEE

ANSI # 150

Housing

Cast steel - ASTM A216/A216M-93 (1998)

Fabricated carbon steel.

Liner - PFA / PVDF / PP

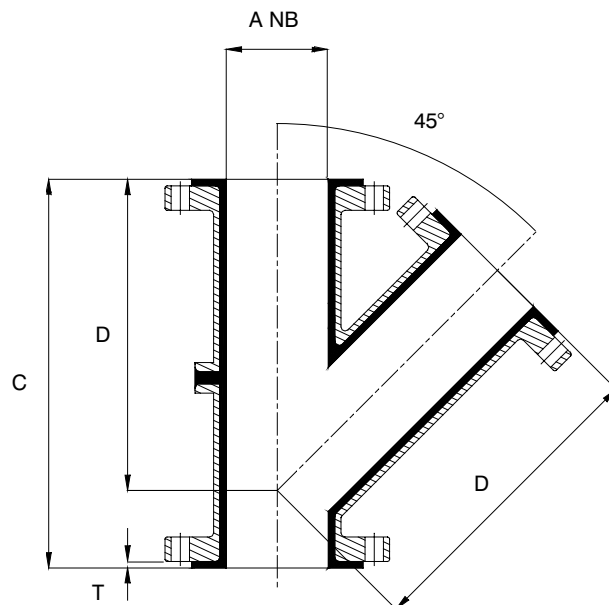

A		C	D	T *	Approx. Weight
inch	mm	mm	mm	mm	~ kg
1	25	191	146	5.6	5
1½	40	229	178	5.6	8
2	50	267	203	5.6	11
3	80	330	254	5.6	24
4	100	381	305	6.4	44
6	150	457	368	7.1	66
8	200	559	445	7.9	100

* T - liner thickness is indicative and may vary slightly from batch to batch
Actual dimensions and tolerances for specific orders are available upon request.

Preface	Manufacturing Specification	Performance Data	Pipes and Fittings – ANSI	Pipes and Fittings – DIN	PTFE expansion bellows	
Sight Flow Indicator	Spectacle Blinds	Ball Check Valve	Level Indicator	Dip Pipes	Nozzle linings	Column Internals

#SURELINE

PIPE SYSTEMS

REDUCING FLANGE

ANSI # 150

Housing

Fabricated carbon steel.

Liner - PFA / PVDF / PP

Code for column X

A = bolt holes on/off centres

B = bolt holes straddle centre lines

C = clearance holes on largest diameter

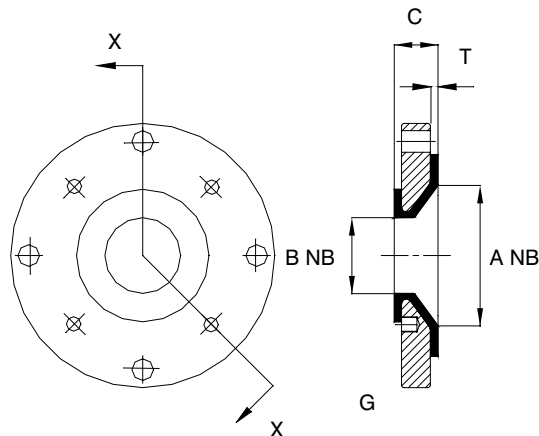

A		B		C	X	T *	Approx. Weight
inch	mm	inch	mm	mm	mm	mm	~ kg
1 ³ / ₄	20	1/2	15	35	A	5.0	1.5
1	25	1/2	15	35	A	5.0	1.5
1	25	3/4	20	35	A	5.0	1.5
1 ¹ / ₄	32	1/2	15	35	A	5.0	1.5
1 ¹ / ₄	32	3/4	20	35	A	5.0	1.5
1 ¹ / ₄	32	1	25	35	A	5.0	1.5
1 ¹ / ₂	40	1/2	15	35	A	5.5	2.1
1 ¹ / ₂	40	3/4	20	35	A	5.5	2.1
1 ¹ / ₂	40	1	25	35	A	5.5	2.1
1 ¹ / ₂	40	1 ¹ / ₄	32	35	A	5.5	2.1
2	50	1/2	15	35	A	6.0	3.0
2	50	3/4	20	35	A	6.0	3.0
2	50	1	25	35	A	6.0	3.0
2	50	1 ¹ / ₄	32	35	A	6.0	3.0
2	50	1 ¹ / ₂	40	35	A	6.0	3.0
2 ¹ / ₂	65	1/2	15	35	A	6.0	4.5
2 ¹ / ₂	65	3/4	20	35	A	6.0	4.5
2 ¹ / ₂	65	1	25	35	A	6.0	4.5
2 ¹ / ₂	65	1 ¹ / ₄	32	35	A	6.0	4.5
2 ¹ / ₂	65	1 ¹ / ₂	40	35	A	6.0	4.5
2 ¹ / ₂	65	2	50	35	A	6.0	4.5
3	80	1	15	35	A	5.5	6.1
3	80	1 ¹ / ₄	20	35	A	5.5	6.1
3	80	1 ¹ / ₂	25	35	A	5.5	6.1
3	80	1 ¹ / ₄	32	35	A	6.0	6.1
3	80	1 ¹ / ₂	40	35	A	6.0	6.1
3	80	2	50	35	A	6.0	6.1
3	80	2 ¹ / ₂	65	35	A	6.0	6.1
4	100	1 ¹ / ₂	25	45	B/C	6.0	8.8
4	100	1 ¹ / ₄	32	45	B/C	6.5	8.8
4	100	1 ¹ / ₂	40	45	B/C	6.5	8.8
4	100	2	50	45	B/C	6.5	8.8
4	100	2 ¹ / ₂	65	45	A	6.5	8.8
4	100	3	80	45	A	6.5	8.8

Preface	Manufacturing Specification	Performance Data	Pipes and Fittings – ANSI	Pipes and Fittings – DIN	PTFE expansion bellows	
Sight Flow Indicator	Spectacle Blinds	Ball Check Valve	Level Indicator	Dip Pipes	Nozzle linings	Column Internals

#SURELINE

PIPE SYSTEMS

REDUCING FLANGE

A		B		C	X	T *	Approx. Weight
inch	mm	inch	mm	mm	Code	mm	~ kg
5	125	1 1/2	25	45	B/C	6.5	11.0
5	125	1 1/4	32	45	B/C	6.5	11.0
5	125	1 1/2	40	45	B/C	6.5	11.0
5	125	2	50	45	B/C	6.5	11.0
5	125	2 1/2	65	45	B/C	6.5	11.0
5	125	3	80	45	B/C	6.5	11.0
5	125	4	100	45	A	6.5	11.0
6	150	1 1/2	25	45	B/C	6.5	13.3
6	150	1 1/4	32	45	B/C	6.5	13.3
6	150	1 1/2	40	45	B/C	6.5	13.3
6	150	2	50	45	B/C	6.5	13.3
6	150	2 1/2	65	45	B/C	6.5	13.3
6	150	3	80	45	B/C	6.5	13.3
6	150	4	100	45	B/C	6.5	13.3
6	150	5	125	45	B	7.0	13.3
8	200	1 1/2	25	45	B	7.0	25
8	200	1 1/4	32	45	B/C	7.0	25
8	200	1 1/2	40	45	B/C	7.0	25
8	200	2	50	45	B/C	7.0	25
8	200	2 1/2	65	45	B/C	7.0	25
8	200	3	80	45	B/C	7.0	25
8	200	4	100	45	B/C	7.0	25
8	200	6	150	45	B	7.5	25
10	250	1 1/2	25	45	B	8.0	36
10	250	1 1/4	32	45	B/C	8.0	36
10	250	1 1/2	40	45	B/C	8.0	36
10	250	2	50	45	B/C	8.0	36
10	250	2 1/2	65	45	B/C	8.0	36
10	250	3	80	45	B/C	8.0	36
10	250	4	100	45	B/C	8.0	36
10	250	5	125	45	B/C	8.0	36
10	250	6	150	45	B/C	8.5	36
10	250	8	200	45	B	9.0	36
12	300	1 1/2	25	45	B/C	9.0	50
12	300	1 1/4	32	45	B/C	9.0	50
12	300	1 1/2	40	45	B/C	9.0	50
12	300	2	50	45	B/C	9.0	50
12	300	2 1/2	65	45	B/C	9.0	50
12	300	3	80	45	B/C	9.0	50
12	300	4	100	45	B/C	9.0	50
12	300	5	125	45	B/C	9.0	50
12	300	6	150	45	B/C	9.0	50
12	300	6	150	45	B/C	9.0	50
12	300	8	200	45	B/C	9.0	50
12	300	10	250	45	B	9.0	50

All bolt holes are threaded UNC for bolt dimensions to ANSI 150#. Bolt penetration into the threaded holes (open or closed off) shall be calculated as bolt diameter x 0.8 plus one complete thread when the assembly is fully torqued.

Preface	Manufacturing Specification	Performance Data	Pipes and Fittings – ANSI	Pipes and Fittings – DIN	PTFE expansion bellows	
Sight Flow Indicator	Spectacle Blinds	Ball Check Valve	Level Indicator	Dip Pipes	Nozzle linings	Column Internals

#SURELINE

PIPE SYSTEMS

Fabrication standards

Qualification of welding procedures, welders and welding operators shall be in accordance with section IX of the ASME Boiler and Pressure Vessel Code or BS 4870 : Part 1 and BS 4871 : Part 1, DIN 8560 or EN-288-3.

All welds shall be visually examined and assessed in accordance with ASME B31.3 or relevant code.

Dimensional standards

Flanged cast steel fittings shall be in accordance with ANSI B16.5 Class 150.

Flanged Ductile Iron fittings shall be in accordance with ANSI B16.42 Class 150.

Fabricated fittings shall be in accordance with the dimensions shown in MB Plastics #Sureline manual.

Pipe diameters and wall thickness' shall be in accordance with the dimension table 1. below.

Flanges for pipe and fittings

Flanges for pipe and fittings shall be in accordance with ANSI B16.5 Class 150.

Flanges shall be slip on welding, socket welding or welding neck types.

Loose backing flanges shall be suitable for use with welding collars.

All relevant dimensions and tolerances shall be in accordance with ANSI B16.5 Class 150.

Threaded bolt holes are not permitted except for reducing flanges. Threaded bolt holes in reducing flanges shall be UNC unless specified otherwise.

Welding collars for use with loose backing flanges shall be slip on welding, socket welding or welding neck type.

The diameters and thickness' shall be as given in dimension table 1. below.

Spacers shall be either solid PTFE or lined steel. The outside diameters shall be as given in dimension table 1. below.

The outside diameter of instrument tee bodies shall be the same as lined spacers.

The minimum wall thickness of the linings shall be as given in dimension Table 1. The lining on the faces of flanges shall have uniform thickness and shall not be less than 80 per cent of the actual wall thickness.

The minimum lining face diameters shall be as given in dimension table 1.

Table 1

NB	Pipe OD	Pipe Sch	Pipe Thk	Collar OD +0 -2	Collar Thk	Spacer OD +0 -2	Min liner thk	Min face dia	Max Pipe length	Min Pipe length
1"	33.4	40	3.38	51	12	66.5	3.0	48	6000	140
1-1/2"	48.3	40	3.68	73	12	85.5	3.0	68	6000	150
2"	60.3	40	3.91	92	14	105.0	3.0	87	6000	150
3"	88.9	40	5.49	127	16	136.5	3.0	117	6000	170
4"	114.3	40	6.02	157	16	174.5	4.0	151	6000	180
6"	168.3	40	7.11	216	18	222.0	5.0	203	3000	205
8"	219.1	30	7.04	270	20	279.5	6.5	256	3000	225
10"	273.1	30	7.80	324	22	339.5	7.5	311	3000	235
12"	323.9	30	8.38	381	22	409.5	8.5	365	3000	255

#SURELINE

PIPE SYSTEMS

SOLID SPACER

ANSI # 150

PTFE
PVDF
PP

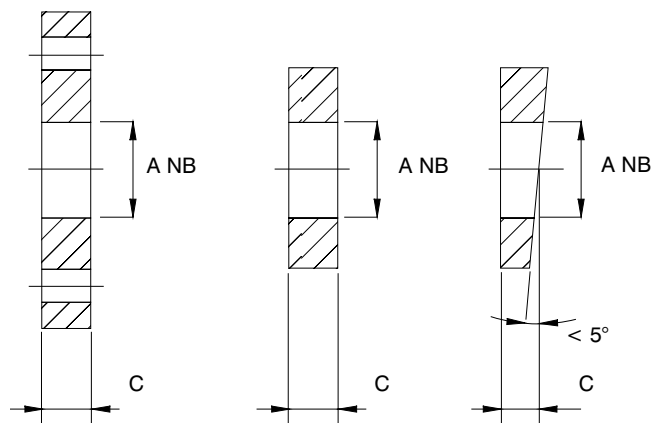

A - inch	A - mm	C - mm min
1/2	15	25
3/4	20	25
1	25	25
1 1/4	32	25
1 1/2	40	25
2	50	25
2 1/2	65	25
3	80	25
4	100	25
5	125	25
6	150	25
8	200	25
10	250	25
12	300	25

Preface	Manufacturing Specification	Performance Data	Pipes and Fittings – ANSI	Pipes and Fittings – DIN	PTFE expansion bellows
Sight Flow Indicator	Spectacle Blinds	Ball Check Valve	Level Indicator	Dip Pipes	Nozzle linings
					Column Internals

#SURELINE

PIPE SYSTEMS

BLANK FLANGE

ANSI # 150

Carbon steel : ASTM A105/A105M-98

Liner :

PTFE - bonded lining

PVD and PP - full face non bonded lining

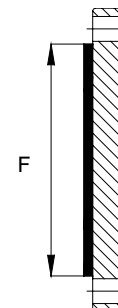

NB - inch	NB - mm	F - mm
1/2	15	35
3/4	20	43
1	25	51
1 1/2	40	73
2	50	92
2 1/2	65	105
3	80	127
4	100	157
5	125	186
6	150	216
8	200	270
10	250	324
12	300	381

Preface	Manufacturing Specification	Performance Data	Pipes and Fittings – ANSI	Pipes and Fittings – DIN	PTFE expansion bellows	
Sight Flow Indicator	Spectacle Blinds	Ball Check Valve	Level Indicator	Dip Pipes	Nozzle linings	Column Internals

#SURELINE

PIPE SYSTEMS

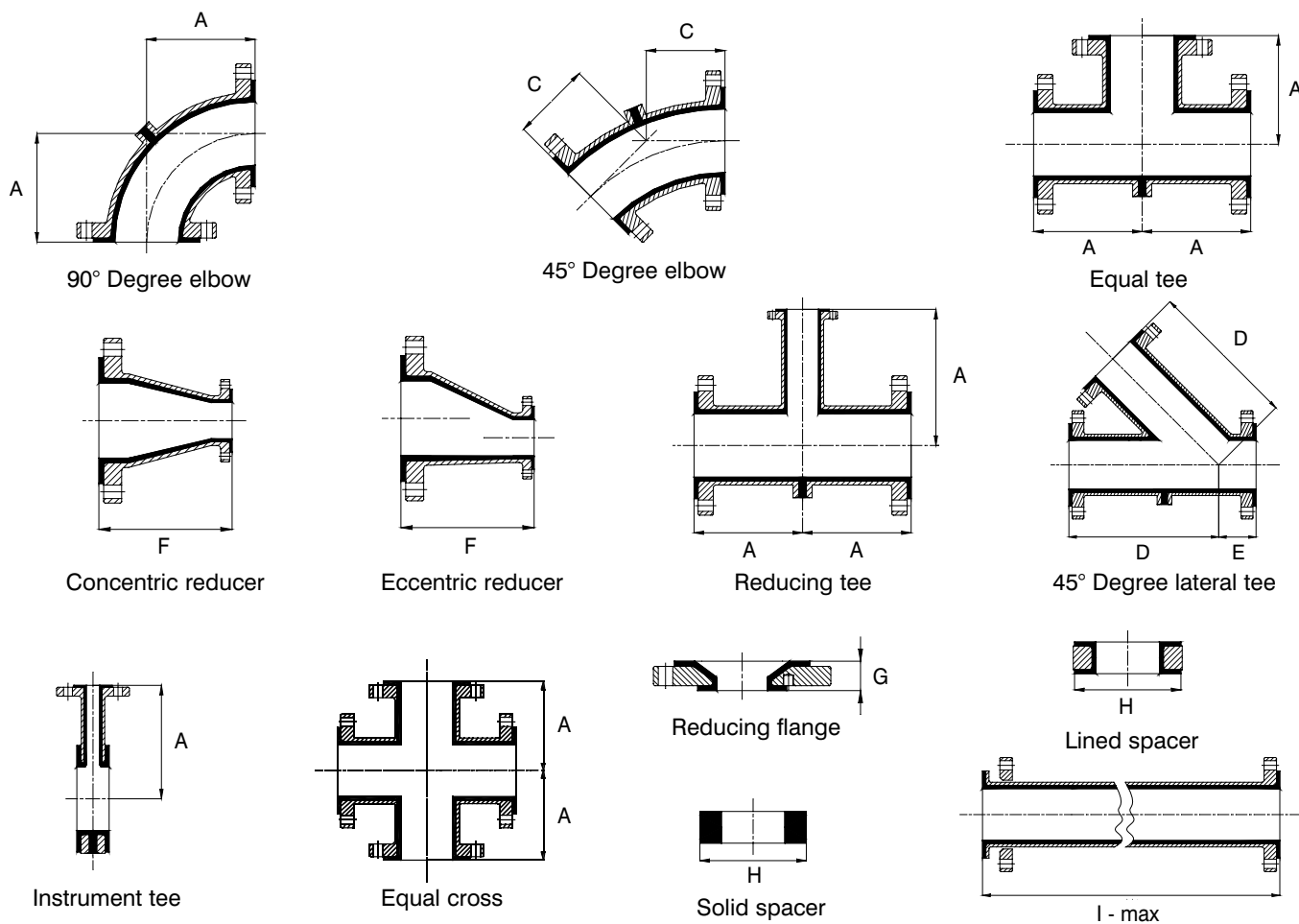

NB	A	C	D	E	F	G	H	I-max	I-max	I-min	I - min
mm	mm	mm	mm	mm	mm	mm	mm	PTFE	PVDF/PP	PTFE	PVDF/PP
15	80	45	*	*	*	*	*	1000	N/A	140	N/A
20	95	50	*	*	*	*	*	1000	N/A	140	N/A
25	110	70	146	45	125	35	70	6000	6000	140	140
40	150	90	178	51	145	35	90	6000	6000	150	150
50	120	80	203	64	160/165	35	105	6000	6000	150	150
80	165	100	254	76	185/190	35	140	6000	6000	170	170
100	205	115	305	76	200/205	45	160	6000	6000	180	180
150	285	150	368	89	250	45	216	6000	6000	205	205
200	365	190	445	114	270	45	271	3000	6000	225	225
250	450	225	*	*	305/310	45	327	3000	3000	235	235
300	525	260	*	*	335/340	45	432	3000	3000	255	255

* information available upon request N/A - not available

Preface	Manufacturing Specification	Performance Data	Pipes and Fittings – ANSI	Pipes and Fittings – DIN	PTFE expansion bellows	
Sight Flow Indicator	Spectacle Blinds	Ball Check Valve	Level Indicator	Dip Pipes	Nozzle linings	Column Internals

#SURELINE

PIPE SYSTEMS

PIPE SPOOL – PTFE

DIN 2848

Housing - fabricated carbon steel

Liner - PTFE

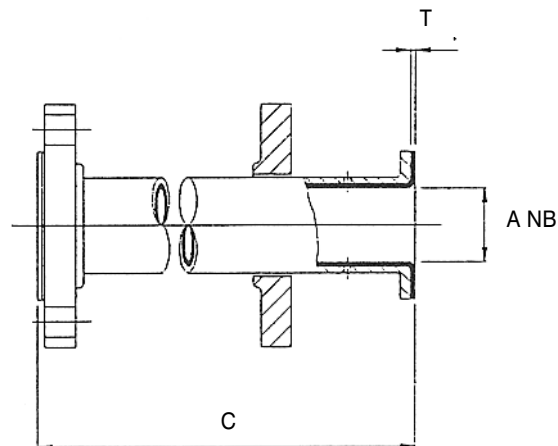

A mm	C max mm	C mini mm	T * mm	Approx. Weight	
				1m ~ kg	+1m ~ kg
15	1000	140	1.50	2.7	1.2
20	1000	140	1.50	3.6	1.6
25	6000	140	3.18	5.0	2.5
32	6000	150	3.18	8.0	3.4
40	6000	150	3.18	8.7	4.5
50	6000	150	3.18	11.3	5.8
65	6000	160	3.18	13.7	7.1
80	6000	170	3.18	18.3	10.0
100	6000	180	4.25	23.9	14.0
125	6000	205	4.75	29.0	17.5
150	6000	205	5.25	39.5	23.5
200	3000	225	6.75	62.0	39.0
250	3000	235	7.75	86.5	55.5
300	3000	255	8.75	113.0	74.0

* T - liner thickness is indicative and may vary slightly from batch to batch
Actual dimensions and tolerances for specific orders are available upon request.

Preface	Manufacturing Specification	Performance Data	Pipes and Fittings – ANSI	Pipes and Fittings – DIN	PTFE expansion bellows	
Sight Flow Indicator	Spectacle Blinds	Ball Check Valve	Level Indicator	Dip Pipes	Nozzle linings	Column Internals

#SURELINE

PIPE SYSTEMS

PIPE SPOOL – PVDF & PP

DIN 2848

Housing - fabricated carbon steel

Liner - PVDF & PP

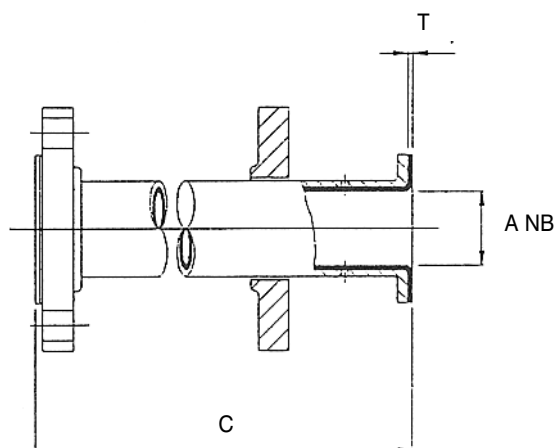

A inch	C max mm	C mini mm	T *		Approx. Weight	
			PVDF	PP	1m ~ kg	+1m ~ kg
25	6000	140	2.54	3.81	5.0	2.5
40	6000	150	2.54	4.06	8.7	4.5
50	6000	150	2.54	4.45	11.3	5.8
80	6000	170	2.54	4.45	18.3	10.0
100	6000	180	2.54	5.33	23.9	14.0
150	6000	205	3.68	5.60	39.5	23.5
200	6000	225	4.06	5.60	62.0	39.0
250	6000	235	5.60	6.35	86.5	55.5
300	6000	255	6.35	6.35	113	74.0

* T - liner thickness is indicative and may vary slightly from batch to batch

Actual dimensions and tolerances for specific orders are available upon request.

Preface	Manufacturing Specification	Performance Data	Pipes and Fittings – ANSI	Pipes and Fittings – DIN	PTFE expansion bellows
Sight Flow Indicator	Spectacle Blinds	Ball Check Valve	Level Indicator	Dip Pipes	Nozzle linings
					Column Internals

#SURELINE

PIPE SYSTEMS

PIPE SPOOL – JACKETED

DIN 2848

Housing - fabricated carbon steel

Liner - PTFE

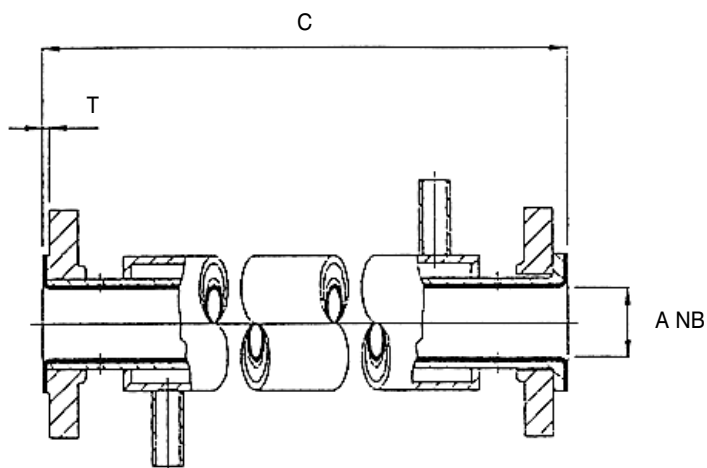

A mm	C max mm	C mini mm	T * mm	Approx. Weight	
				1m ~ kg	+1m ~ kg
25	6000	140	3.18	10	7
40	6000	150	3.18	14	10
50	6000	150	3.18	23	18
80	6000	170	3.18	37	29
100	6000	180	4.25	59	47
150	6000	205	5.25	87	71
200	3000	225	6.75	127	103
250	3000	235	7.75	166	128
300	3000	255	8.75	203	164

Jackets for pipe diameter 25 through 100mm are supplied in schedule 40, whereas diameter 150 through 300mm are supplied in schedule 30.

* T - liner thickness is indicative and may vary slightly from batch to batch
Actual dimensions and tolerances for specific orders are available upon request.

#SURELINE

PIPE SYSTEMS

90° ELBOW

DIN 2848

Housing

S.G. Iron - BS EN 1563:1997 (BS2789:1985)

Cast steel - ASTM A216/A216M-93 (1998)

Liner - PFA / PVDF / PP

PTFE lined elbows are available within fabricated carbon steel housings.

Liner thickness and overall weight may vary from information below.

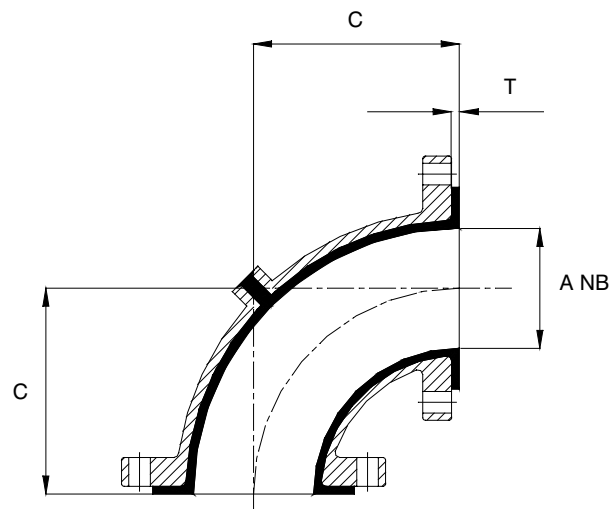

A	C	T *	Approx. Weight
mm	mm	mm	~ kg
15	80	1.50	1.5
20	95	1.50	2.1
25	110	5.60	2.7
32	130	3.20	4.0
40	150	5.60	4.6
50	120	5.60	7.0
65	220	3.20	7.5
80	165	5.60	14
100	205	6.40	24
125	385	4.75	18
150	285	7.10	48
200	365	7.90	91
250	450	7.90	147
300	525	9.50	189

* T - liner thickness is indicative and may vary slightly from batch to batch
Actual dimensions and tolerances for specific orders are available upon request.

Preface	Manufacturing Specification	Performance Data	Pipes and Fittings – ANSI	Pipes and Fittings – DIN	PTFE expansion bellows
Sight Flow Indicator	Spectacle Blinds	Ball Check Valve	Level Indicator	Dip Pipes	Nozzle linings
					Column Internals

#SURELINE

PIPE SYSTEMS

45° ELBOW

DIN 2848

Housing

S.G. Iron - BS EN 1563:1997 (BS2789:1985)

Liner - PFA / PVDF / PP

PTFE lined elbows are available within fabricated carbon steel housings.

Liner thickness and overall weight may vary from information below.

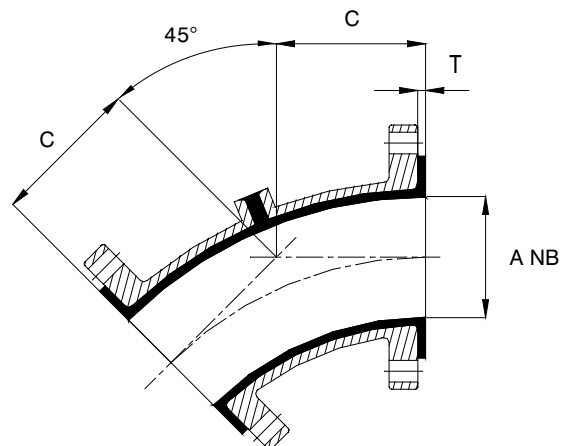

A	C	T *	Approx. Weight
mm	mm	mm	~ kg
15	45	1.50	1.6
20	50	1.50	2.1
25	70	5.60	2.8
32	98	3.00	4.0
40	90	5.60	4.7
50	80	5.60	5.9
65	104	3.20	7.6
80	100	5.60	9.4
100	115	6.40	12.1
125	166	4.75	17.5
150	150	7.10	21.0
200	190	7.90	33.1
250	225	7.90	48.5
300	260	9.50	66.0

* T - liner thickness is indicative and may vary slightly from batch to batch
Actual dimensions and tolerances for specific orders are available upon request.

Preface	Manufacturing Specification	Performance Data	Pipes and Fittings – ANSI	Pipes and Fittings – DIN	PTFE expansion bellows	
Sight Flow Indicator	Spectacle Blinds	Ball Check Valve	Level Indicator	Dip Pipes	Nozzle linings	Column Internals

#SURELINE

PIPE SYSTEMS

EQUAL TEE

DIN 2848

Housing

S.G. Iron - BS EN 1563:1997 (BS2789:1985)

Fabricated carbon steel

Liner - PFA / PVDF / PP

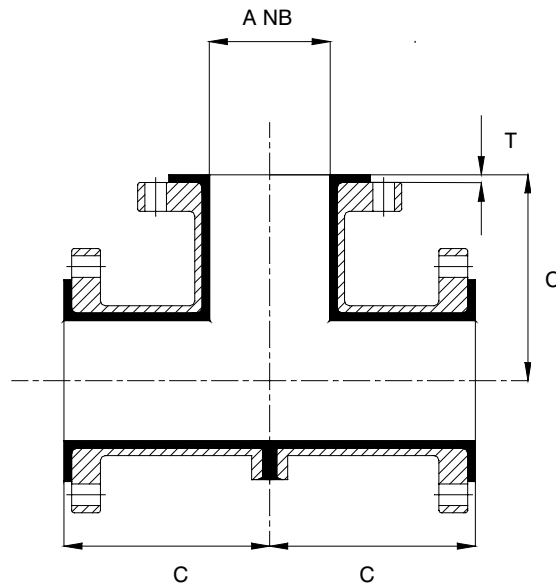

A	C	T *	Approx. Weight
mm	mm	mm	~ kg
15	80	2.9	2.5
20	95	2.9	3.2
25	110	5.6	5.6
32	110	5.6	7.0
40	150	5.6	9.4
50	120	5.6	9.4
65	140	5.6	14
80	165	5.6	21
100	205	6.4	37
125	245	6.4	53
150	285	7.1	77
200	365	7.9	80
250	450	7.9	120
300	525	9.5	160

* T - liner thickness is indicative and may vary slightly from batch to batch
Actual dimensions and tolerances for specific orders are available upon request.

Preface	Manufacturing Specification	Performance Data	Pipes and Fittings – ANSI	Pipes and Fittings – DIN	PTFE expansion bellows
Sight Flow Indicator	Spectacle Blinds	Ball Check Valve	Level Indicator	Dip Pipes	Nozzle linings
					Column Internals

#SURELINE

PIPE SYSTEMS

REDUCING TEE

DIN 2848

Housing

S.G. Iron - BS EN 1563:1997 (BS2789:1985)

Fabricated carbon steel

Liner - PFA / PVDF / PP

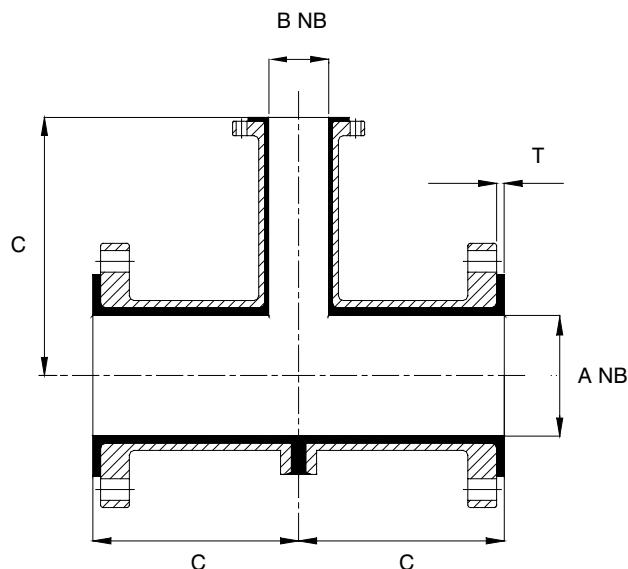

A	B	C	D	T*	Weight	A	B	C	D	T*	Weight
mm	mm	mm	mm	mm	~ kg	mm	mm	mm	mm	mm	~ kg
25	15	95	80	5.6	3.1	200	25	365	235	7.9	61.2
25	20	110	95	5.6	3.9	200	40	365	245	7.9	65.7
40	15	150	80	5.6	5.3	200	50	365	250	7.9	67.7
40	20	150	100	5.6	5.5	200	80	365	250	7.9	77.4
40	25	150	110	5.6	5.7	200	100	365	260	7.9	83.0
50	25	120	110	5.6	9.3	200	150	365	285	7.9	130
50	40	120	150	5.6	9.8	250	150	450	285	7.9	156
80	25	165	110	5.6	19.7	250	200	450	365	7.9	161
80	40	165	150	5.6	20.4	300	150	525	325	9.5	165
80	50	165	120	5.6	20.9	300	200	525	365	9.5	218
100	25	205	110	6.4	31.4	300	250	525	450	9.5	222
100	40	205	150	6.4	33.3						
100	50	205	120	6.4	34.1						
100	80	205	165	6.4	36.0						
150	25	285	205	7.1	40.7						
150	40	285	215	7.1	44.6						
150	50	285	220	7.1	51.5						
150	80	285	165	7.1	56.2						
150	100	285	205	7.1	77.0						

Note : Reduced tees with main bore diameters 32, 65 and 125mm are also available

* T - liner thickness is indicative and may vary slightly from batch to batch

Actual dimensions and tolerances for specific orders are available upon request.

Preface	Manufacturing Specification	Performance Data	Pipes and Fittings – ANSI	Pipes and Fittings – DIN	PTFE expansion bellows	
Sight Flow Indicator	Spectacle Blinds	Ball Check Valve	Level Indicator	Dip Pipes	Nozzle linings	Column Internals

#SURELINE

PIPE SYSTEMS

CONCENTRIC REDUCER

DIN 2848

Housing

S.G. Iron - BS EN 1563:1997

(BS2789:1985)

Fabricated carbon steel

Liner - PFA / PVDF / PP

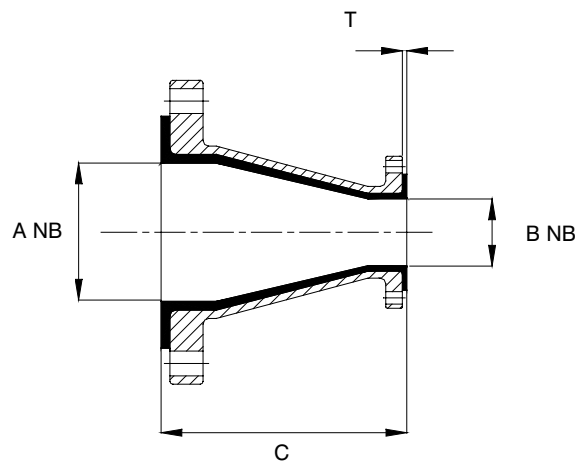

A	B	C	T*	Weight	A	B	C	T*	Weight
mm	mm	mm	mm	= kg	mm	mm	mm	mm	~ kg
25	15	125	3.0	2.4	150	25	250	7.1	19.0
25	20	125	3.0	2.3	150	40	250	7.1	19.5
40	15	145	5.6	3.0	150	80	250	7.1	17.4
40	20	145	5.6	3.1	150	100	250	7.1	18.3
40	25	145	5.6	3.3	200	100	270	7.9	22.1
50	25	160	5.6	4.1	200	150	270	7.9	25.2
50	40	165	5.6	4.8	250	100	305	7.9	31.0
80	25	185	5.6	6.7	250	150	305	7.9	35.0
80	40	185	5.6	6.3	250	200	310	7.9	37.8
80	50	190	5.6	6.9	300	200	335	9.5	48.0
80	65	190	5.6	7.5	300	250	340	9.5	52.6
100	25	200	6.4	10.2					
100	40	200	6.4	10.0					
100	50	200	6.4	9.4					
100	65	200	6.4	9.9					
100	80	205	6.4	10.6					

Other reducers, with main bores of 125, 65 and 32mm are also available.

* T - liner thickness is indicative and may vary slightly from batch to batch

Actual dimensions and tolerances for specific orders are available upon request.

MB Plastics reserves the right, dependant upon product availability, delivery schedules etc, to supply reducers as a composite fitting composed of a reducer and a reducing flange(s).

Preface	Manufacturing Specification	Performance Data	Pipes and Fittings – ANSI	Pipes and Fittings – DIN	PTFE expansion bellows	
Sight Flow Indicator	Spectacle Blinds	Ball Check Valve	Level Indicator	Dip Pipes	Nozzle linings	Column Internals

#SURELINE

PIPE SYSTEMS

ECCENTRIC REDUCER

DIN 2848

Housing

Fabricated carbon steel

Liner - PFA / PVDF / PP

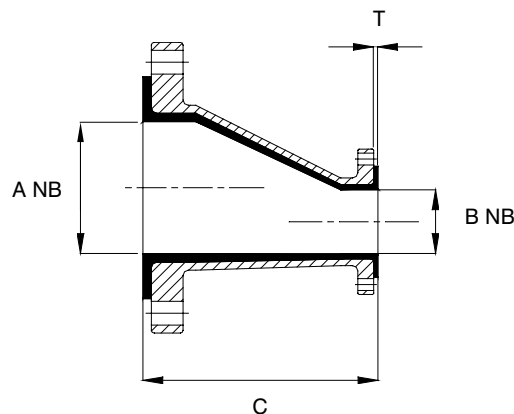

A	B	C	T *	Weight
mm	mm	mm	mm	~ kg
25	20	125	3.0	2.3
40	25	145	5.6	3.3
50	40	165	5.6	4.8
80	50	190	5.6	6.9
80	65	190	5.6	7.5
100	65	200	6.4	9.9
100	80	205	6.4	10.6
150	100	250	7.1	18.3
150	125	250	7.1	17.4
200	150	270	7.9	25.2
250	200	310	7.9	37.8
300	250	340	9.5	52.6

Other reducers, with main bores of 125, 65 and 32mm are also available.

* T - liner thickness is indicative and may vary slightly from batch to batch.

Actual dimensions and tolerances for specific orders are available upon request.

MB Plastics reserves the right, dependant upon product availability, delivery schedules etc, to supply reducers as a composite fitting composed of a reducer and a reducing flange(s).

Preface	Manufacturing Specification	Performance Data	Pipes and Fittings – ANSI	Pipes and Fittings – DIN	PTFE expansion bellows	
Sight Flow Indicator	Spectacle Blinds	Ball Check Valve	Level Indicator	Dip Pipes	Nozzle linings	Column Internals

#SURELINE

PIPE SYSTEMS

INSTRUMENT TEE

DIN 2848

Housing

S.G. Iron - BS EN 1563:1997 (BS2789:1985)

Fabricated carbon steel

Liner : PFA

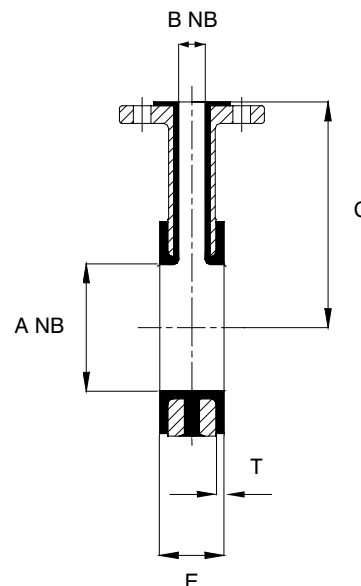

B			20mm		25mm		32mm		40mm		50mm	
A	C	T**	E	~kg	E	~kg	E	~kg	E	~kg	E	~kg
mm	mm	mm	mm	mm	mm	mm	mm	mm	mm	mm	mm	mm
25	90	5.6	50	3.55	50	3.55	n/a	n/a	n/a	n/a	n/a	n/a
32	100	5.6	50	4.36	50	4.36	n/a	n/a	n/a	n/a	n/a	n/a
40	110	5.6	50	5.41	50	5.41	75	6.74	75	8.06	n/a	n/a
50	115	5.6	50	6.32	50	6.32	75	7.87	75	9.42	90	11.0
65	125	5.6	50	6.78	50	6.78	75	8.44	75	10.1	90	11.8
80*	135	5.6	50	7.84	50	7.84	75	9.77	75	11.7	90	13.7
100*	150	6.4	50	8.90	50	8.90	75	11.1	75	13.3	90	15.5
125	160	6.4	50	10.8	50	10.8	75	13.5	75	16.1	90	18.9
150	180	7.1	50	13.4	50	13.4	75	16.6	75	19.9	90	23.3
200	210	7.9	50	17.5	50	17.5	75	21.7	75	26.0	90	30.5
250	240	7.9	50	20.4	50	20.4	75	25.4	75	30.4	90	35.6
300	340	7.9	90	24.0	90	24.0	110	29.9	110	35.7	120	41.8

* 8 - Hole patterns require threaded bolt holes on 50mm branch items

** T - liner thickness is indicative and may vary slightly from batch to batch
Actual dimensions and tolerances for specific orders are available upon request.

Preface	Manufacturing Specification	Performance Data	Pipes and Fittings – ANSI	Pipes and Fittings – DIN	PTFE expansion bellows	
Sight Flow Indicator	Spectacle Blinds	Ball Check Valve	Level Indicator	Dip Pipes	Nozzle linings	Column Internals

#SURELINE

PIPE SYSTEMS

INSTRUMENT TEE

DIN 2848

Housing : Fabricated carbon steel –

Body plate : BS EN 10273:2000

(BS2789:1985)

Pipe : API 5L Gr.B.

Flange : ASTM A105/A105M-98

Liner : PVDF & PP

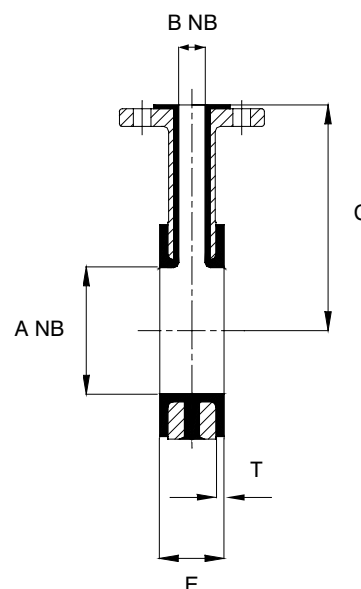

B			20mm		25mm		32mm		40mm		50mm	
A	C	T**	E	~kg	E	~kg	E	~kg	E	~kg	E	~kg
mm	mm	mm	mm	mm	mm	mm	mm	mm	mm	mm	mm	mm
25	90	5.6	50	2.37	50	2.37	n/a	n/a	n/a	n/a	n/a	n/a
32	100	5.6	50	2.77	50	2.77	n/a	n/a	n/a	n/a	n/a	n/a
40	110	5.6	50	3.08	50	3.08	75	4.02	75	4.96	n/a	n/a
50	115	5.6	50	3.60	50	3.60	75	4.70	75	5.80	90	7.92
65	125	5.6	50	4.44	50	4.44	75	5.78	75	7.12	90	10.2
80*	135	5.6	50	5.13	50	5.13	75	6.65	75	8.16	90	11.9
100*	150	6.4	50	5.91	50	5.91	75	7.64	75	9.37	90	14.0
125	160	6.4	50	7.28	50	7.28	75	9.41	75	11.5	90	17.8
150	180	7.1	50	8.37	50	8.37	75	10.8	75	13.2	90	20.6
200	210	7.9	50	12.6	50	12.6	75	14.1	75	17.4	90	27.2
250	240	7.9	50	14.7	50	14.7	75	16.5	75	20.4	90	31.7
300	340	7.9	90	17.3	90	17.3	110	19.5	110	23.9	120	37.2

* Hole patterns require threaded bolt holes on 50mm branch items

**T - liner thickness is indicative and may vary slightly from batch to batch

Actual dimensions and tolerances for specific orders are available upon request.

Preface	Manufacturing Specification	Performance Data	Pipes and Fittings – ANSI	Pipes and Fittings – DIN	PTFE expansion bellows	
Sight Flow Indicator	Spectacle Blinds	Ball Check Valve	Level Indicator	Dip Pipes	Nozzle linings	Column Internals

#SURELINE

PIPE SYSTEMS

EQUAL CROSS

DIN 2848

Housing - Fabricated carbon steel.

Liner - PFA / PVDF / PP

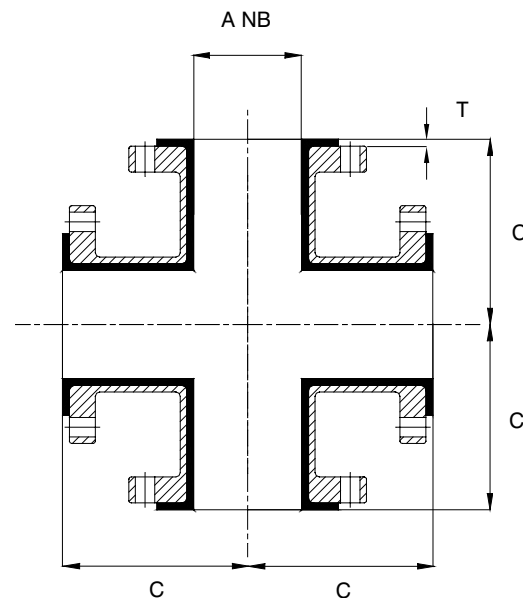

A	C	T *	Approx. Weight
mm	mm	mm	~ kg
15	80	2.9	3.5
20	95	2.9	4.5
25	110	5.6	5.1
32	130	5.6	9.5
40	150	5.6	12.4
50	120	5.6	12.5
65	220	5.6	15.0
80	165	5.6	29.0
100	205	6.4	49.0
125	245	6.5	80.0
150	285	7.1	99.0
200	365	7.9	108
250	450	7.9	210

*T - liner thickness is indicative and may vary slightly from batch to batch
Actual dimensions and tolerances for specific orders are available upon request.

Preface	Manufacturing Specification	Performance Data	Pipes and Fittings – ANSI	Pipes and Fittings – DIN	PTFE expansion bellows
Sight Flow Indicator	Spectacle Blinds	Ball Check Valve	Level Indicator	Dip Pipes	Nozzle linings
					Column Internals

#SURELINE

PIPE SYSTEMS

LATERAL TEE

DIN 2848

Housing

Cast steel ASTM A216/A216M-98

Fabricated carbon steel.

Liner - PFA / PVDF / PP

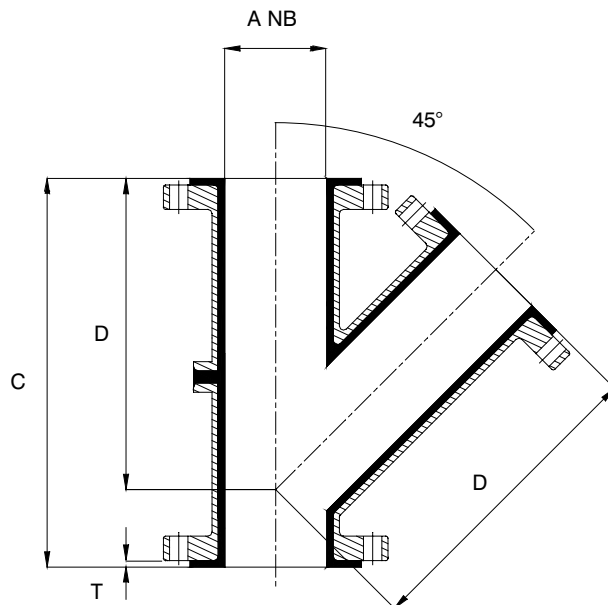

A	C	D	T *	Weight
mm	mm	mm	mm	~ kg
25	191	146	5.6	5
40	229	178	5.6	8
50	267	203	5.6	11
80	330	254	5.6	24
100	381	305	6.4	44
150	457	368	7.1	66
200	559	445	7.9	100

*T - liner thickness is indicative and may vary slightly from batch to batch
Actual dimensions and tolerances for specific orders are available upon request.

#SURELINE

PIPE SYSTEMS

REDUCING FLANGE

DIN 2848

Housing

Fabricated carbon steel.

Liner - PFA / PVDF / PP

Code for column X

A = bolt holes on/off centres

B = bolt holes straddle centre lines

C = clearance holes on largest diameter

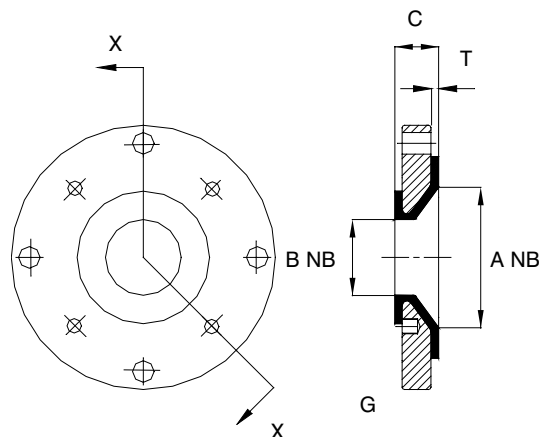

A mm	B mm	C mm	X Code	T * mm	Approx. Weight ~ kg
20	15	30	A	5.0	1.5
25	15	30	A	5.0	1.5
25	20	30	A	5.0	1.5
32	15	30	A	5.0	1.5
32	20	30	A	5.0	1.5
32	25	30	A	5.0	1.5
40	15	30	A	5.5	2.1
40	20	30	A	5.5	2.1
40	25	30	A	5.5	2.1
40	32	30	A	5.5	2.1
50	15	30	A	6.0	3.0
50	20	30	A	6.0	3.0
50	25	30	A	6.0	3.0
50	32	30	A	6.0	3.0
50	40	30	A	6.0	3.0
65	15	30	A	6.0	4.5
65	20	30	A	6.0	4.5
65	25	30	A	6.0	4.5
65	32	30	A	6.0	4.5
65	40	30	A	6.0	4.5
65	50	30	A	6.0	4.5
80	15	30	A	5.5	6.1
80	20	30	A	5.5	6.1
80	25	30	A	5.5	6.1
80	32	30	A	6.0	6.1
80	40	30	A	6.0	6.1
80	50	30	A	6.0	6.1
80	65	30	A	6.0	6.1
100	25	45	B/C	6.0	8.8
100	32	45	B/C	6.5	8.8
100	40	45	B/C	6.5	8.8
100	50	45	B/C	6.5	8.8

*T - liner thickness is indicative and may vary slightly from batch to batch

Actual dimensions and tolerances for specific orders are available upon request.

Preface	Manufacturing Specification	Performance Data	Pipes and Fittings – ANSI	Pipes and Fittings – DIN	PTFE expansion bellows
Sight Flow Indicator	Spectacle Blinds	Ball Check Valve	Level Indicator	Dip Pipes	Nozzle linings
					Column Internals

#SURELINE

PIPE SYSTEMS

REDUCING FLANGE

A	B	C	X	T *	Approx. Weight
mm	mm	mm	Code	mm	~ kg
100	65	45	A	6.5	8.8
100	80	45	A	6.5	8.8
125	25	45	B/C	6.5	11.0
125	32	45	B/C	6.5	11.0
125	40	45	B/C	6.5	11.0
125	50	45	B/C	6.5	11.0
125	65	45	B/C	6.5	11.0
125	80	45	B/C	6.5	11.0
125	100	45	A	6.5	11.0
150	25	45	B/C	6.5	13.3
150	32	45	B/C	6.5	13.3
150	40	45	B/C	6.5	13.3
150	50	45	B/C	6.5	13.3
150	65	45	B/C	6.5	13.3
150	80	45	B/C	6.5	13.3
150	100	45	B/C	6.5	13.3
150	125	45	B	7.0	13.3
200	25	45	B	7.0	25
200	32	45	B/C	7.0	25
200	40	45	B/C	7.0	25
200	50	45	B/C	7.0	25
200	65	45	B/C	7.0	25
200	80	45	B/C	7.0	25
200	100	45	B/C	7.0	25
200	150	45	B	7.5	25
250	25	45	B	8.0	36
250	32	45	B/C	8.0	36
250	40	45	B/C	8.0	36
250	50	45	B/C	8.0	36
250	65	45	B/C	8.0	36
250	80	45	B/C	8.0	36
250	100	45	B/C	8.0	36
250	125	45	B/C	8.0	36
250	150	45	B/C	8.5	36
250	200	45	B	9.0	36
300	25	45	B/C	9.0	50
300	32	45	B/C	9.0	50
300	40	45	B/C	9.0	50
300	50	45	B/C	9.0	50
300	65	45	B/C	9.0	50
300	80	45	B/C	9.0	50
300	100	45	B/C	9.0	50
300	125	45	B/C	9.0	50
300	150	45	B/C	9.0	50
300	200	45	B/C	9.0	50
300	250	45	B	9.0	50

Preface	Manufacturing Specification	Performance Data	Pipes and Fittings – ANSI	Pipes and Fittings – DIN	PTFE expansion bellows
Sight Flow Indicator	Spectacle Blinds	Ball Check Valve	Level Indicator	Dip Pipes	Nozzle linings
					Column Internals

#SURELINE

PIPE SYSTEMS

LINED SPACER

DIN 2848

Housing : Carbon steel

Liner : PFA, PVDF and PP.

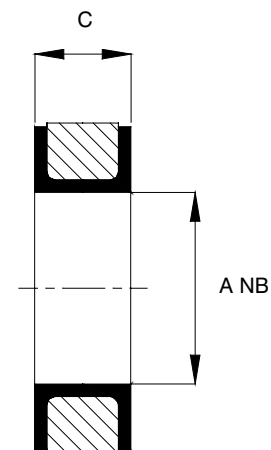

A - mm	C - mm min
15	20
20	20
25	20
32	20
40	20
50	20
65	25
80	25
100	25
125	30
150	30
200	30
250	40
300	40

#SURELINE

PIPE SYSTEMS

SOLID SPACER

DIN 2848

PTFE
PVDF
PP

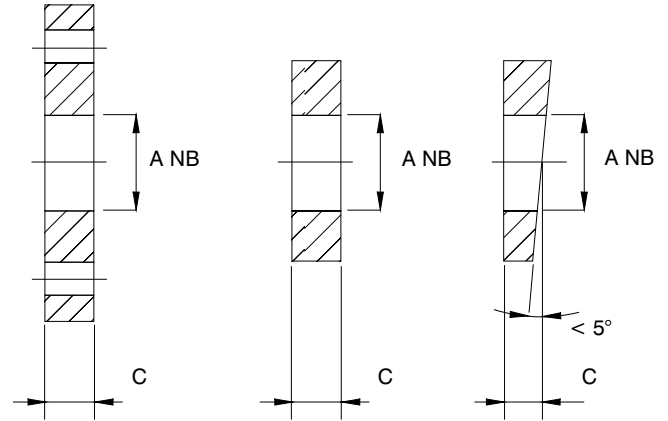

A - mm	C - mm min
15	25
20	25
25	25
32	25
40	25
50	25
65	25
80	25
100	25
125	25
150	25
200	25
250	25
300	25

Preface	Manufacturing Specification	Performance Data	Pipes and Fittings – ANSI	Pipes and Fittings – DIN	PTFE expansion bellows	
Sight Flow Indicator	Spectacle Blinds	Ball Check Valve	Level Indicator	Dip Pipes	Nozzle linings	Column Internals

#SURELINE

PIPE SYSTEMS

BLANK FLANGE

DIN 2848

Carbon steel : ASTM A 105N

Liner :

PTFE - bonded lining

PVDF & PP - full face non bonded lining

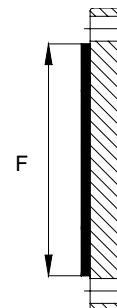

NB - mm	F - mm
15	35
20	43
25	51
40	73
50	92
65	105
80	127
100	157
125	186
150	216
200	270
250	324
300	381

Preface	Manufacturing Specification	Performance Data	Pipes and Fittings – ANSI	Pipes and Fittings – DIN	PTFE expansion bellows
Sight Flow Indicator	Spectacle Blinds	Ball Check Valve	Level Indicator	Dip Pipes	Nozzle linings
					Column Internals

#SURELINE

PIPE SYSTEMS

MB Plastics has developed material and production technology which allows the company to offer not only the wide range of standard PTFE expansion bellows described in the following pages, but also an almost unlimited range of purpose designed and built bellows, to suit a wide range of applications and design conditions, at a most competitive price level.

Typical applications include expansion and anti vibration joints, connections which allow a high level of misalignment, and one piece coupling systems which replace multi fitting configurations in difficult or confined areas of a production plant. Bellows for diameters over and above 300mm are also available upon request, and are often specified for handling aggressive fumes and gases.

Possible non standard configurations include joints with up to 10 convolutions, different diameters at either end of the bellow, or a combination of both cylindrical and convoluted items in one bellow. Non standard bellows are available as one off prototypes for trial purposes, or as small to medium size production runs for bellows designed to resolve multiple and identical problems within a specific production system.

Both standard and non-standard bellows can be supplied with flanges to all major manufacturing standards (ANSI/BS/DIN/NF/EN/JIS etc)

The high level of chemical resistance of the PTFE material used offers the possibility for the end user to use these bellows with a wide range of piping and vessel materials, including glass, lined carbon steel and stainless steel, composite and flexible materials up to service temperatures as high as 230°C, depending upon the nature of the fluid being handled and the service pressure.

#SURELINE

PIPE SYSTEMS

PTFE EXPANSION BELLOW - 2 CONVOLUTIONS

- Stainless steel reinforcing rings with Hastelloy as an option.
- Cadmium plated flanges to ANSI B16.5 Class 150.
- One piece contour moulded PTFE body with integral flange covering.
- Full vacuum rating to 4" diameter at 200°C.
- Safety factor of 4 with a burst pressure approximately 4 times maximum working pressure (see pressure: temperature chart).
- Maximum permitted angular deflection is approximately 7°.

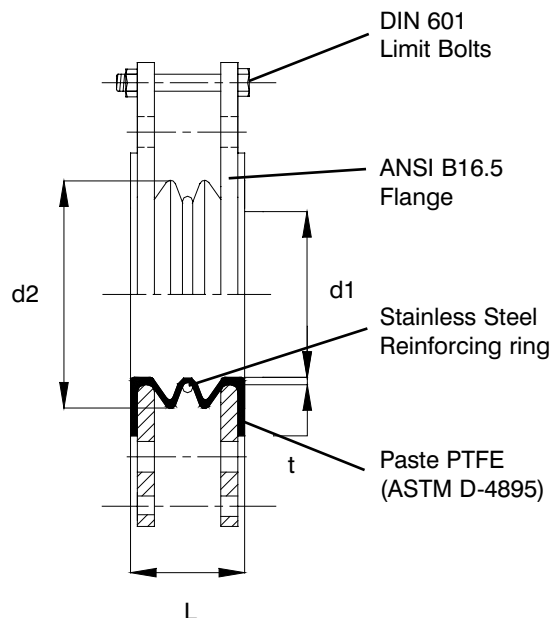

DN		Length	Axial	Lateral Misalignment	Vacuum resistance	at max	Compression resistance	Extension resistance	t±10%	d1±10%	d2±10%
inch	mm	(L)mm	±mm	±mm	10 ⁴ N/m ²	°C	N/mm	N/mm	mm	mm	mm
1/2	15	28	4	2	0.1	200	20	19	2	12	25
3/4	20	28	4	2	0.1	200	23	21	2	18	34
1	25	35	6	3	0.1	200	26	24	3	24	43
1 1/2	40	35	6	3	0.1	200	81	63	3	57	57
2	50	40	6	3	0.1	200	140	90	3	50	75
2 1/2	65	57	9	5	0.1	200	159	102	3	60	91
3	80	57	9	5	0.1	200	170	120	3.5	76	104
4	100	67	13	6	0.1	200	194	130	4	100	134
5	125	83	13	6	0.1	150	230	138	4.25	122	163
6	150	75	13	6	0.1	150	263	145	4.5	150	188
8	200	102	13	6	0.1	50	380	157	5.25	204	250
					2.0	150					
10	250	140	15	6	0.7	45	212	156	5.25	255	325
					3.4	100					
12	300	150	20	10	1.5	45	200	158	5.5	280	345
					6.7	100					

#SURELINE

PIPE SYSTEMS

PTFE EXPANSION BELLOW - 2 CONVOLUTIONS

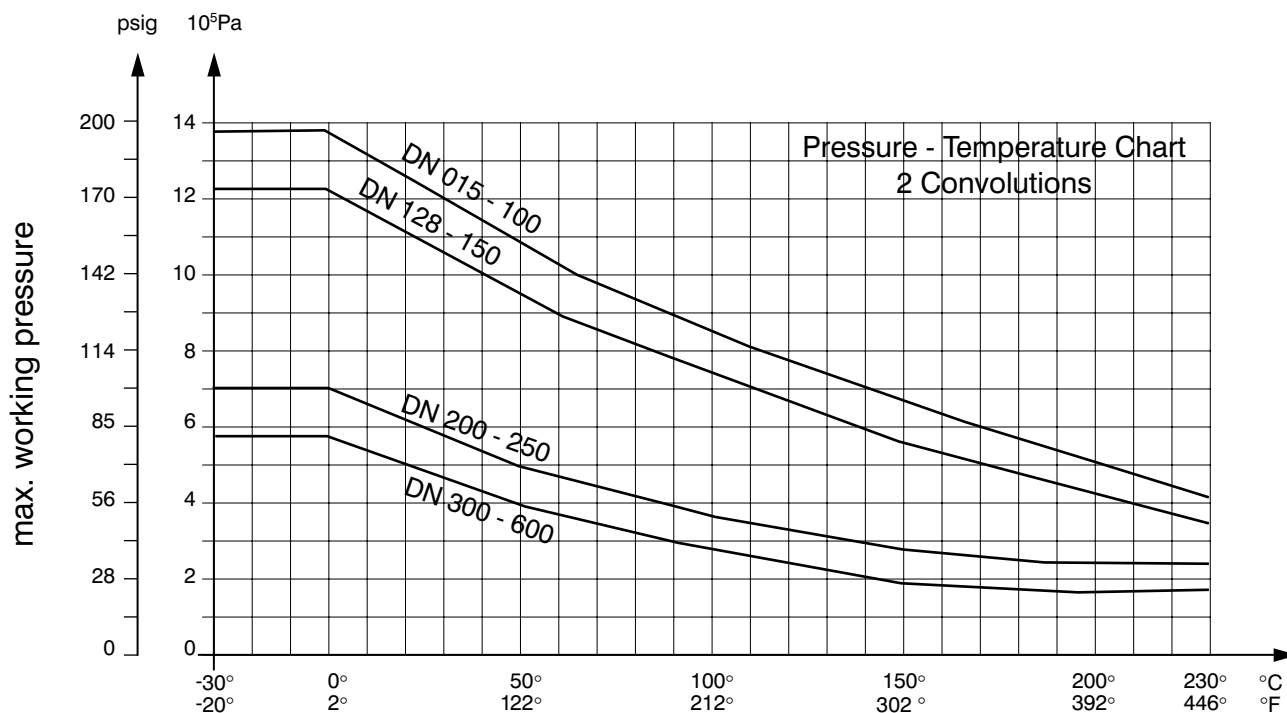

DN		Effective bellows cross-section cm ²	Weight kg
Inch	mm		
1/2	15	3	1.2
3/4	20	5	1.5
1	25	10	1.6
1 1/2	40	19	2.5
2	50	30	3.6
2 1/2	65	45	4.4
3	80	70	5.2
4	100	112	6.9
5	125	166	11.2
6	150	245	12.3
8	200	400	20
10	250	660	26
12	300	770	33

- Pressure rated from -30°C/-20°F to +230°C/+440°F.
- Burst pressure is approximately 4 times the maximum working pressure as shown on the chart above.
- Maximum permitted angular deflection is approximately 7°.
- Each expansion joint has two (2) extension limitation bolts.
- The values given are averages and relate to ambient temperature. Deviations due to processing conditions may occur.
- Please contact our sales office for sizes above 12"/ 300mm.

#SURELINE

PIPE SYSTEMS

PTFE EXPANSION BELLOW - 3 CONVOLUTIONS

- Stainless steel reinforcing rings with Hastelloy as an option.
- Cadmium plated flanges to ANSI B16.5 Class 150.
- One piece contour moulded PTFE body with integral flange covering.
- Full vacuum rating to 4" diameter at 200°C.
- Safety factor of 4 with a burst pressure approximately 4 times maximum working pressure (see pressure: temperature chart).
- Maximum permitted angular deflection is approximately 14°.
- Pressure rated from -30°C/-20°F to +230°C/+440°F.
- Burst pressure is approximately 4 times the maximum working pressure as shown on the chart above.

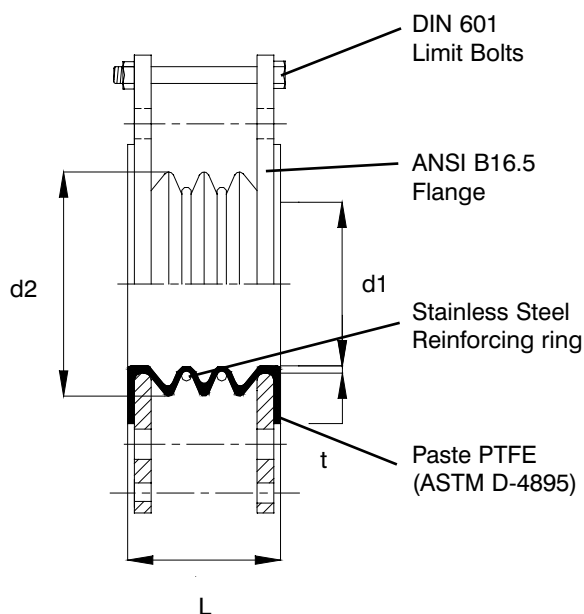

DN		Length	Axial	Lateral Misalignment	Vacuum resistance	at max	Compression resistance	Extension resistance	t±10%	d1±10%	d2±10%
inch	mm	(L)mm	±mm	±mm	10 ⁴ N/m ²	°C	N/mm	N/mm	mm	mm	mm
1/2	15	37	6	4	0.1	200	18	17	2	12	25
3/4	20	37	6	4	0.1	200	20	20	2	18	34
1	25	46	13	6	0.1	200	25	21	3	24	43
1 1/2	40	50	13	6	0.1	200	63	51	3	57	57
2	50	56	15	9	0.1	200	81	64	3	50	75
2 1/2	65	77	19	9	0.1	200	124	84	3	60	91
3	80	77	25	13	0.1	200	155	100	3.5	76	104
4	100	91	25	13	0.1	200	175	104	4	100	134
5	125	111	25	14	0.1	150	197	105	4.25	122	163
6	150	101	28	14	0.1	150	220	108	4.5	150	188
8	200	137	28	14	0.1	50	264	90	5.25	204	250
					2.0	150					
10	250	200	30	14	0.7	45	190	93	5.25	255	325
					3.4	100					
12	300	196	30	15	1.5	45	180	95	5.5	280	345
					6.7	100					

#SURELINE

PIPE SYSTEMS

PTFE EXPANSION BELLOW - 3 CONVOLUTIONS

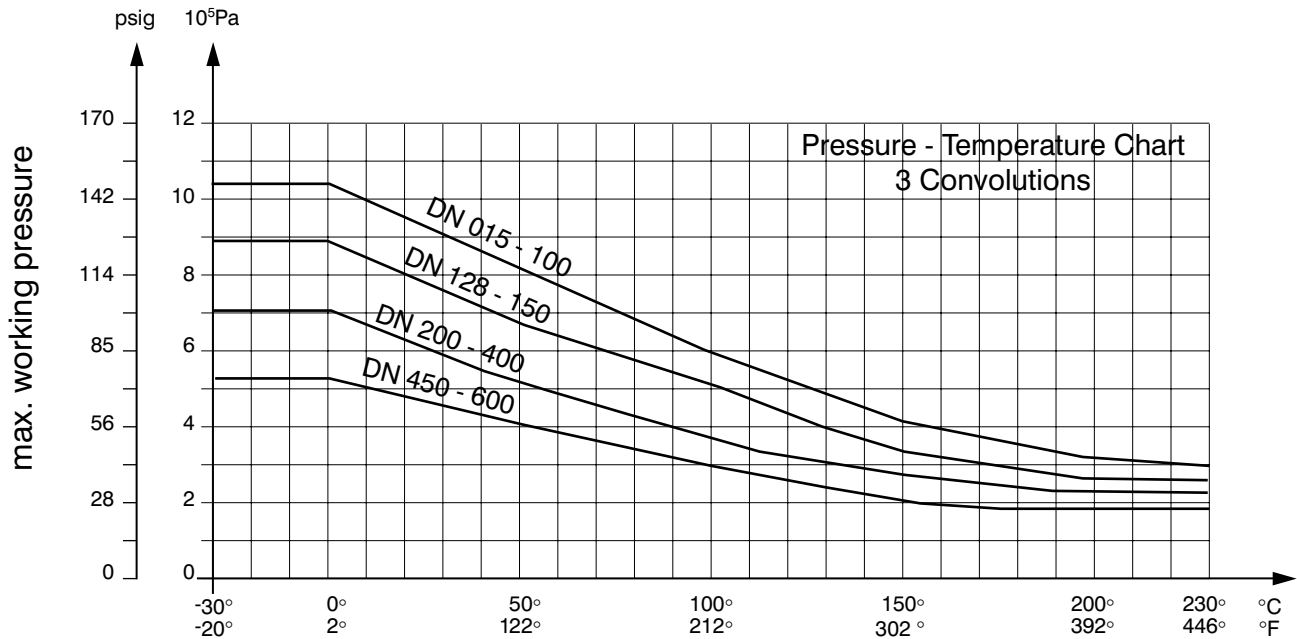

DN Inch	mm	Effective bellows cross-section cm ²	Weight kg
1/2	15	3	1.2
3/4	20	5	1.6
1	25	10	1.7
1 1/2	40	19	2.6
2	50	30	3.8
2 1/2	65	45	4.6
3	80	70	5.3
4	100	112	7.0
5	125	166	11.4
6	150	245	12.7
8	200	400	21
10	250	660	27
12	300	770	35

- Maximum permitted angular deflection is approximately 14°.
- Each expansion joint has two (2) extension limitation bolts.
- The values given are averages and relate to ambient temperature. Deviations due to processing conditions may occur.
- Please contact our sales office for sizes above 12" / 300mm.

#SURELINE

PIPE SYSTEMS

PTFE EXPANSION BELLOW - 5 CONVOLUTIONS

- Stainless steel reinforcing rings with Hastelloy as an option.
- Cadmium plated flanges to ANSI B16.5 Class 150.
- One piece contour moulded PTFE body with integral flange covering.
- Not recommended for vacuum service.
- Safety factor of 4 with a burst pressure approximately 4 times maximum working pressure (see pressure: temperature chart).
- Maximum permitted angular deflection is approximately 20°.

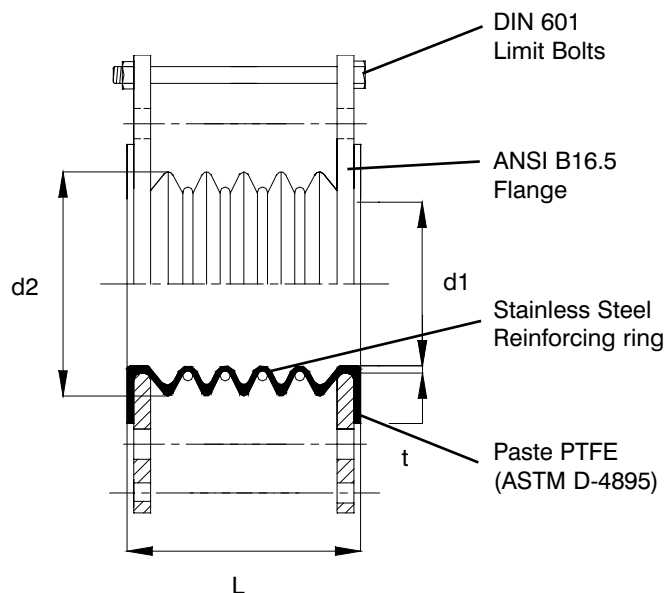

DN		Length	Axial	Lateral Misalignment	Compression resistance	Extension resistance	t±10%	d1±10%	d2±10%
inch	mm	(L)mm	±mm	±mm	N/mm	N/mm	mm	mm	mm
1/2	15	55	8	5	18	17	2	12	25
3/4	20	55	8	5	20	19	2	18	34
1	25	68	8	12	23	20	3	24	43
1 1/2	40	80	13	12	55	40	3	57	57
2	50	88	19	12	97	43	3	50	75
2 1/2	65	117	25	13	102	56	3	60	91
3	80	117	25	16	114	62	3.5	76	104
4	100	139	25	16	127	67	4	100	134
5	125	167	32	16	139	68	4.25	122	163
6	150	153	32	16	150	68	4.5	150	188
8	200	207	32	16	177	68	5.25	204	250
10	250	300	32	16	150	68	5.25	255	325
12	300	288	35	18	155	78	5.5	280	345

#SURELINE

PIPE SYSTEMS

PTFE EXPANSION BELLOW - 5 CONVOLUTIONS

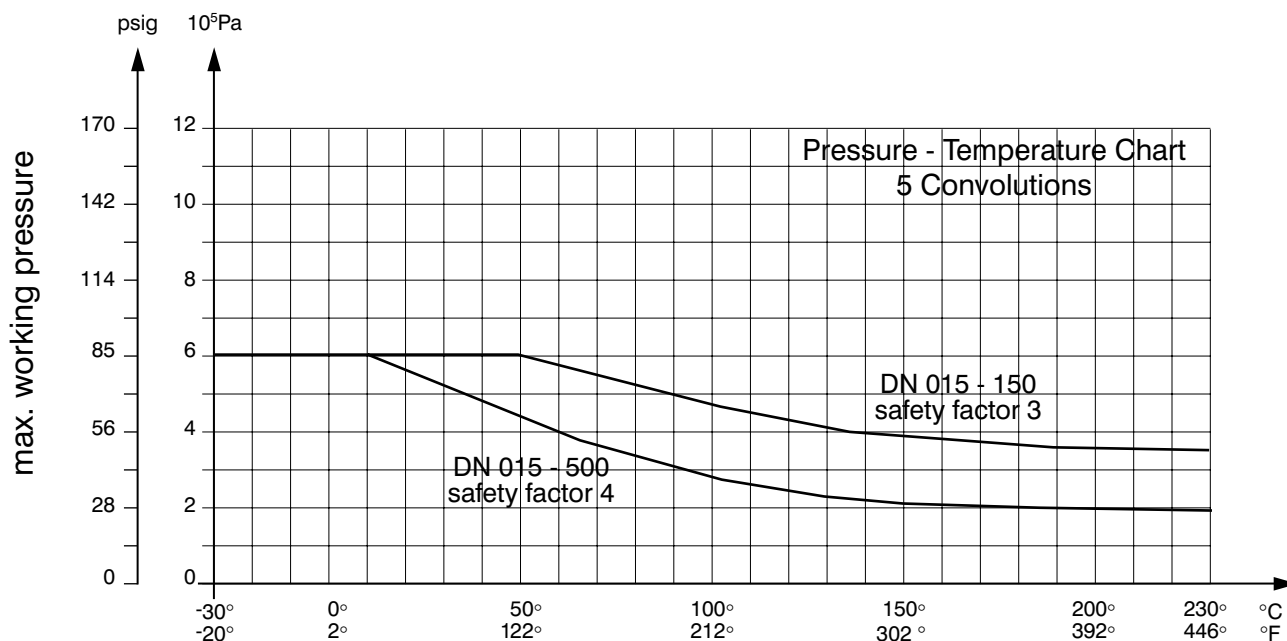

DN		Effective bellows cross-section cm ²	Weight kg
Inch	mm		
1/2	15	3	1.3
3/4	20	5	1.7
1	25	10	1.9
1 1/2	40	19	2.7
2	50	30	4.3
2 1/2	65	45	5.0
3	80	70	5.4
4	100	112	7.1
5	125	166	12
6	150	245	14.2
8	200	400	22
10	250	660	29
12	300	770	40

- Pressure rated from -30°C/-20°F to +230°C/+440°F.
- Burst pressure is approximately 4 times the maximum working pressure as shown on the chart above.
- Maximum permitted angular deflection is approximately 20°.
- Each expansion joint has two (2) extension limitation bolts.
- The values given are averages and relate to ambient temperature. Deviations due to processing conditions may occur.
- Please contact our sales office for sizes above 12"/300mm.

#SURELINE

PIPE SYSTEMS

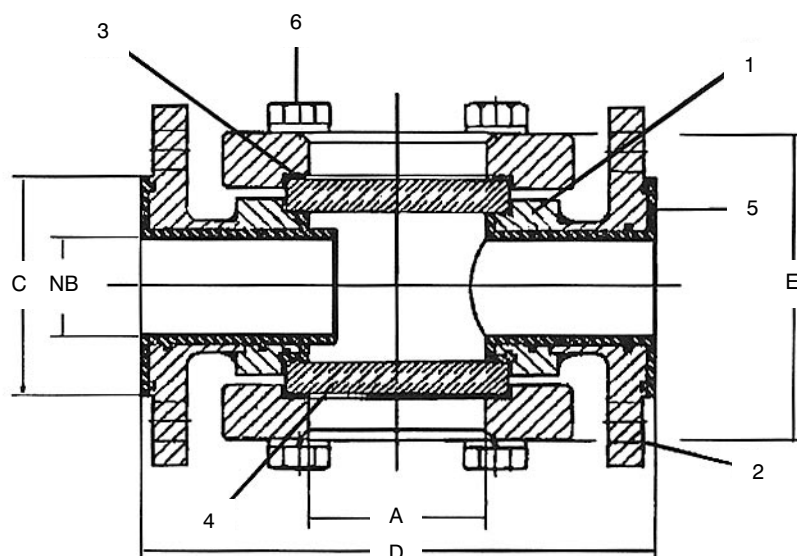

Item	Designation	Material
1	Body	ASTM A105 / ASTM A 216 WCB
2	Flange	ASTM A 105
3	Gasket	IT 150 non asbestos
4	Glass	Borosilicate Toughened Glass
5	Lining	PFA to ASTM D 3307 type S
6	Bolt	AISI 304

NB	A	C	D	E
1/2	32	35	130	80
1	48	51	152	97
1 1/2	65	73	178	125
2	80	92	203	141
3	100	127	241	190
4	125	158	292	220
6	142	216	480	290
8	142	270	600	345

Preface	Manufacturing Specification	Performance Data	Pipes and Fittings – ANSI	Pipes and Fittings – DIN	PTFE expansion bellows	
Sight Flow Indicator	Spectacle Blinds	Ball Check Valve	Level Indicator	Dip Pipes	Nozzle linings	Column Internals

#SURELINE

PIPE SYSTEMS

Spectacle and line blinds are available in a wide range of materials, including;

- PTFE.
- Polypropylene.
- PTFE lined steel.
- Polypropylene lined steel.
- FEP lined steel.

Our range of standard dimensions are shown below. Other dimensions are available to suit particular applications.

NB	A	B	C	D	E
25	50	25	50	138	28
40	70	40	70	158	43
50	90	50	90	182	58
80	125	80	125	220	78
100	155	100	155	258	44
150	214	150	214	310	60

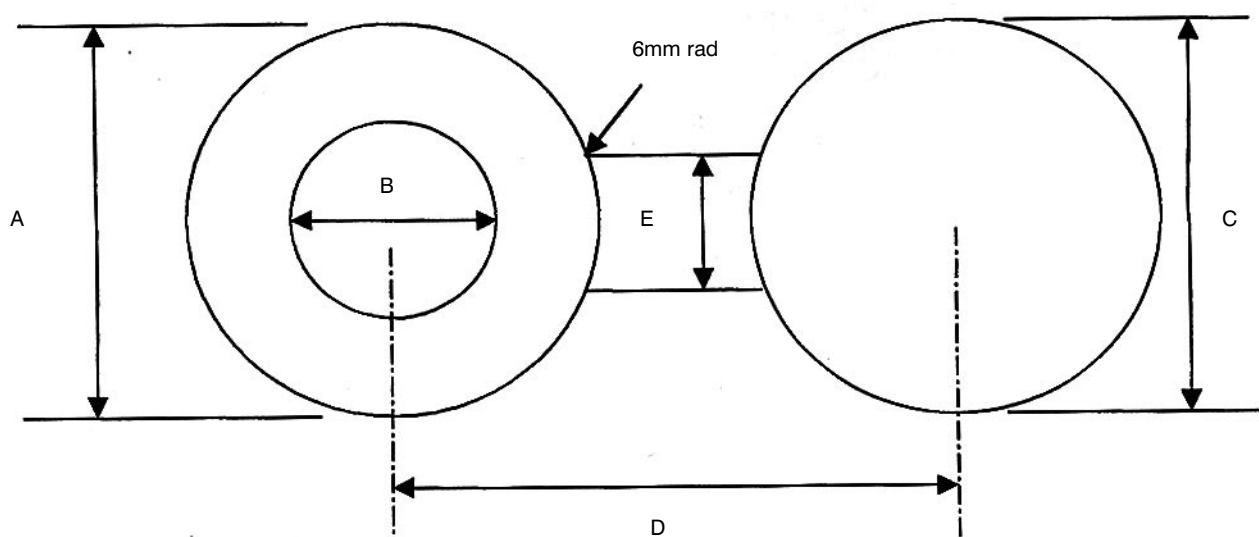

Preface	Manufacturing Specification	Performance Data	Pipes and Fittings – ANSI	Pipes and Fittings – DIN	PTFE expansion bellows
Sight Flow Indicator	Spectacle Blinds	Ball Check Valve	Level Indicator	Dip Pipes	Nozzle linings
					Column Internals

#SURELINE

PIPE SYSTEMS

PTFE lined ball check valve for vertical installation

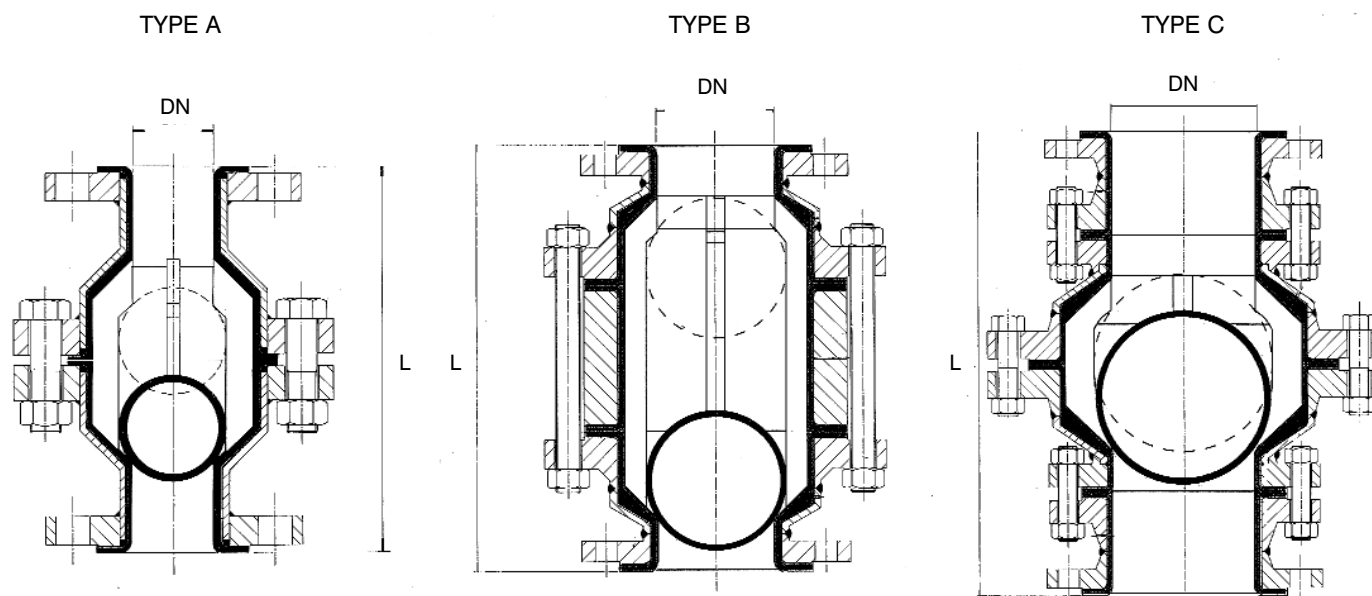

DIN 2848 PN 10				
NB mm	L - mm	ø ball mm	Type	Weight kg
15	130	25	A	4.0
20	150	30	A	4.5
25	160	35	A	5.0
32	180	46	A	7.5
40	200	50	A	8.5
50	230	60	A	12.5
65	290	75	B	20.5
80	310	90	B	22.0
100	350	115	B	31.0
150	480	155	C	59.0
200	600	200	C	93.0

ANSI B 16-5 Class 150				
NB mm	L - mm	ø ball mm	Type	Weight kg
1/2	108	25	A	3.5
3/4	117	30	A	4.0
1	127	35	A	4.5
1 1/4	140	46	A	6.5
1 1/2	165	50	A	8.0
2	178	60	A	12.5
2 1/2	190	75	A	21.0
3	203	90	A	23.0
4	229	115	A	33.0
6	268	155	A	59.0
8	292	200	A	70.0

Versions with solid or hollow PTFE ball.

* Face to face class 150 - BS 2080 "short"

ISO 5752 "short".

Preface	Manufacturing Specification	Performance Data	Level Indicator	Pipes and Fittings – ANSI	Pipes and Fittings – DIN	PTFE expansion bellows
Sight Flow Indicator	Spectacle Blinds	Ball Check Valve	Level Indicator	Dip Pipes	Nozzle linings	Column Internals

#SURELINE

PIPE SYSTEMS

- Less prone to mechanical damage than traditional glass level indicators
- Metal parts fabricated from stainless or carbon steel
- Transparent FEP or PFA lining offersexcellent resistance to most chemicals
- Pressure rating dependant on temperatureup to 150 psi available
- Optional outer guard
- Optional PTFE float ball for applications where the liquid level line is difficult to see.

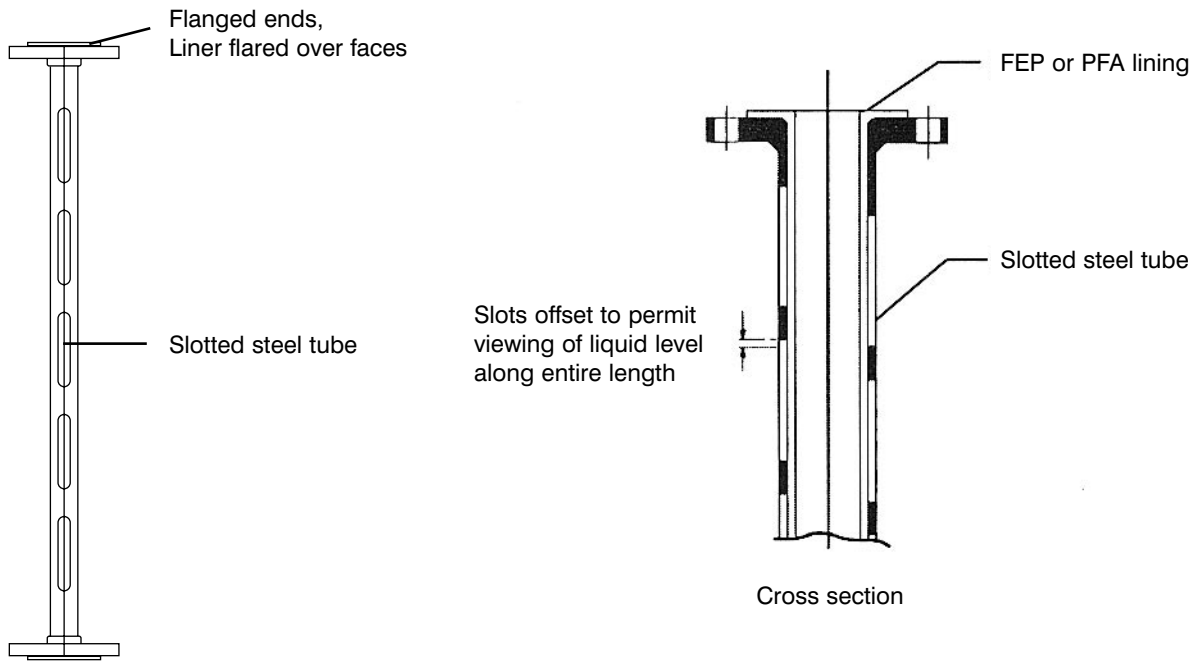

Preface	Manufacturing Specification	Performance Data	Pipes and Fittings – ANSI	Pipes and Fittings – DIN	PTFE expansion bellows	
Sight Flow Indicator	Spectacle Blinds	Ball Check Valve	Level Indicator	Dip Pipes	Nozzle linings	Column Internals

#SURELINE

PIPE SYSTEMS

DIP PIPES

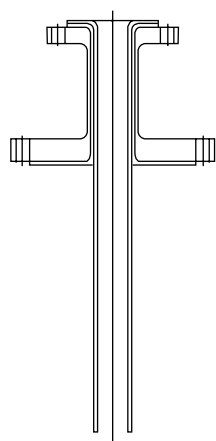

Spitter pipe.

Spitter pipes supplied with FEP or PTFE linings are used when the dip pipe does not penetrate the surface of the liquid contents of the vessel, or if the contents of the vessel are not subject to agitation.

The flanged section consists of an FEP lined steel spool piece which is then fitted with an additional heavy wall PTFE pipe. This pipe is flared over the top flange, and extends through the vessel flange to give the required insertion length. This type of dip pipe offers a very cost effective solution for this basic design.

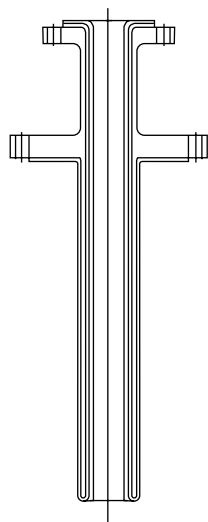

Dip Pipe.

MB Plastics offers a conventional carbon steel dip pipe lined with FEP.

A secondary heavy duty PTFE lining is fitted into the bore and flared over the top of the flange when ever vacuum services conditions are specified.

Many variations of this basic design are available, including multi dip systems.

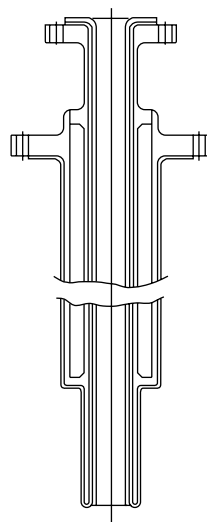

Reinforced dip pipes.

A complex FEP lined concept is used in applications which require a long dip pipe which may also penetrate into highly agitated fluids inside the vessel.

Additional strength is achieved by a system which reinforces the dip pipe with a larger diameter outer pipe.

All wetted surfaces are lined with FEP, and a secondary PTFE inner liner can be fitted when vacuum conditions are specified.

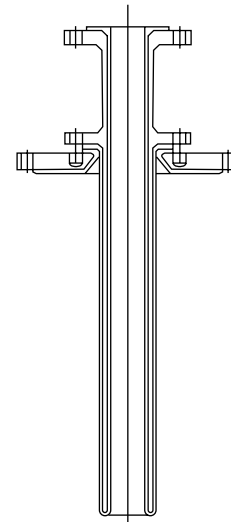

PTFE lined dip pipe.

The basis for this system is a conventional carbon steel dip pipe, on to which a PTFE lining is applied as an integral continuous one piece liner without any welds or seams.

The lining process used requires an intermediate adapter flange in order to assemble the pipe to the vessel. This intermediate flange is also lined with PTFE.

#SURELINE

PIPE SYSTEMS

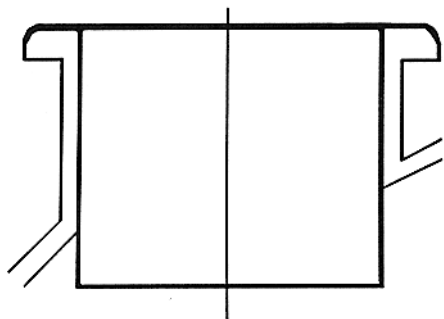

Approx. 12mm edge protection lip

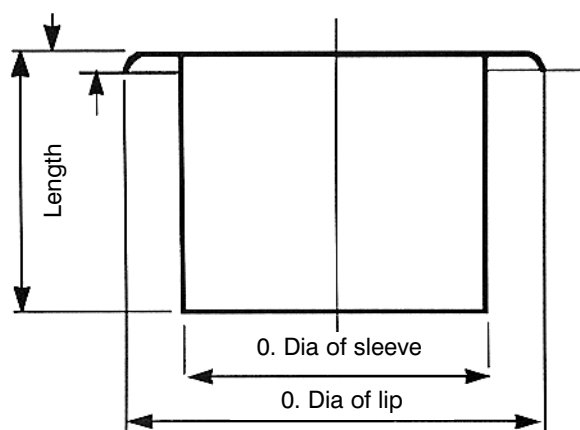

- FEP/PFA nozzle liners offer protection to branches and flange faces on glass enamel equipment. At the same time as affording protection against mechanical damage, the liner can also act as simple dip pipe, avoiding contact between aggressive chemicals and the vessel cover.
- All standard sizes are generally manufactured from 1.5 mm thick material, but thicker material can be supplied if required.
- The dimensions indicated in the table below are suitable for most glass enamel vessels. It is however recommended that actual dimensions of both the nozzle and the associated flange are checked prior to ordering a nozzle liner.
- Non standard dimensions can be supplied to order.

NB Inch	mm	Sleeve OD mm	Lip ID mm
3	80	73	127
4	100	99	152
5	125	124	178
6	150	149	203
8	200	200	254
10	250	251	330
12	300	302	381
18	450	457	559

Preface	Manufacturing Specification	Performance Data	Pipes and Fittings – ANSI	Pipes and Fittings – DIN	PTFE expansion bellows
Sight Flow Indicator	Spectacle Blinds	Ball Check Valve	Level Indicator	Dip Pipes	Nozzle linings
					Column Internals

#SURELINE

PIPE SYSTEMS

MB Plastics offers a full design, fabrication and installation service for a wide range of internal equipment for columns and vessels.

This equipment is generally designed and manufactured to the specific requirements of a particular process, column or vessel, thus offering optimum performance for the end user.

Materials

The materials used are selected from our full range of standard or high performance thermoplastic and fluoropolymer materials, including;

PTFE - Polytetrafluoroethylene

PFA - Perfluoro-alkoxy

FEP - Fluorinated ethylene propylene

E-CTFE - Ethylene-chlorotrifluoroethylene

PVDF - Polyvinylidene fluoride

PP - Polypropylene

PE - Polyethylene

PVC - Polyvinyl chloride

PVC-C - Chlorinated polyvinyl chloride

Product range

The range of equipment on offer varies from relatively standard equipment to special one off designs for unique or trial applications.

This equipment can include,

- Dip pipes
- Sparge pipes
- Distributors
- Demister pads
- Hold down grids
- Support grids
- Packings

The technical staff of MB Plastics are available for detailed discussions around any specific requirements, and are able to offer their high performance thermoforming and welding technologies in order to resolve a wide range of either design or manufacturing problems.