

GRAPHITE INDIA LIMITED



C-7, MIDC, Ambad, Nashik
Maharashtra, INDIA



1967

'Graphite India Limited' (GIL) commenced manufacturing Graphite Electrodes as well as Carbon & Graphite Speciality products in 1967 in collaboration with Great Lakes Carbon Corporation of USA.

1983

In 1983, GIL collaborated with Vicarb SA, France & started an integrated facility for design, manufacture and supply of Graphite Heat Exchangers & Turnkey Systems under the name 'Graphite Vicarb'.
Collaboration lasted till 1994 as Vicarb was sold out.

1995

The name of company was changed to Carbon Everflow Ltd. in 1995 after merger of Nashik based company divisions (Graphite Electrodes, Equipment & Glass Reinforced Plastics division).

2002

Final consolidation took place in 2002 when all group companies were merged under the name 'Graphite India Ltd'.

Graphite India Limited – Group



Graphite Electrode Division (GE)



Impervious Graphite Equipment Division (IGE)



Glass Fibre Reinforced Plastic Pipes Division (GRP)



Coke Division



Powmex Steel Division

Graphite Electrode Division:

Durgapur (West Bengal)

IGE Division:

Nashik (Maharashtra)

GRP Division: Nashik (Maharashtra)

Group company: Graphite COVA GmbH (Nuremberg, Germany)

Graphite India Limited – Impervious Graphite Equipment Division

We are amongst leading Graphite equipment manufacturers in the world.

Our products - **Heat and Mass transfer Equipment, Turn-key systems** - with proven excellence in performance are designed and manufactured to handle corrosive chemicals.

Thermal, Process and Mechanical Design

Process automation

After-sales services

Everything under one roof



ISO 9001:2015 Certification by TÜV Nord

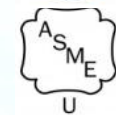

ASME “U” Stamp



The National Board “R” Stamp



The National Board “NB” Stamp



Impervious Graphite as a Material of construction

Following are the attributes that make graphite employable in chemical process industries:

- ▶ Excellent corrosion resistance to many chemicals i.e. organic, inorganic, acid, etc.
- ▶ Outstanding heat transfer properties, particularly good thermal conductivity
- ▶ Good machinability
- ▶ Higher resistance to thermal and mechanical shocks
- ▶ Economical as compared to exotic metals
- ▶ Good withstanding at higher temperature without creeping or degrading
- ▶ Simple bonding technique

Graphite required for manufacturing chemical process equipment is synthetic graphite.

- Graphite rods/blocks are produced by extrusion / molding.
- Raw graphite after manufacturing is porous in nature and hence it is impregnated to make it impervious.
- Material comprises around 90% graphite material and balance resin which fills the pores.

Typical Physical Properties of Impregnated Graphite	Blocks	Tubes
Density gm/cc	1.8-1.9	1.8-1.9
Thermal Conductivity W/m°C	170-213	74-89
Tensile Strength N/mm ²	20-24	27-33
Flexural Strength N/mm ²	30-36	45-56
Compressive Strength N/mm ²	60-70	75-90
Co-efficient of thermal expansion mm/mm/°C x 10 ⁻⁶	3-4	3-4
Permeability cm ² /sec x 10 ⁻⁶	2-3	3-4

General Suitability: Phenolic Impregnated Graphite: **190° C**, PTFE Impregnated Graphite: **230° C**

Manufacturing Process

Raw Graphite To Impervious Graphite Equipment

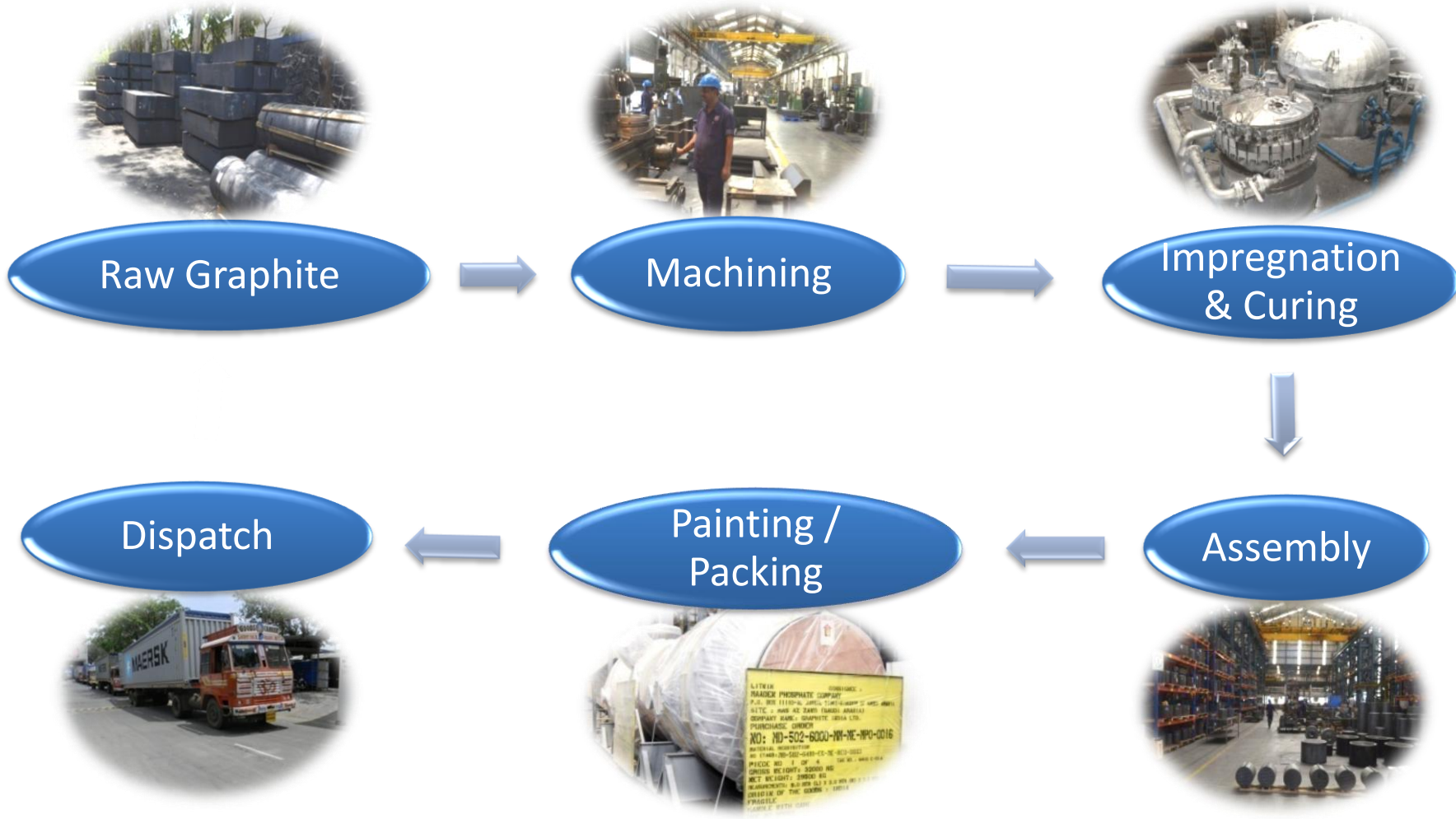

Sectors and Applications

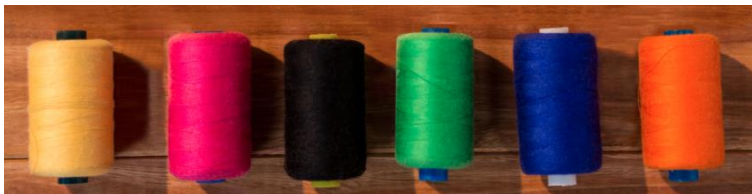

Chlor – Alkali

Pharmaceutical Intermediates

Agrochemicals & Pesticides

**Phosphoric Acid in Phosphate
Fertilizers and Food Industries**

**Chlorinated Organic, Speciality and
Fine Chemicals**

**Steel Pickling & other metal
(Aluminium, copper, etc.) processing**

Batteries & Gelatine

Polymers

Rayon

Dyes Intermediates & Pigments

Product Range

EQUIPMENT

▶ GRAPHITE HEAT EXCHANGERS

Block type heat exchanger

- Monoblock
- Polyblock

Cylindrical & Cubical

Shell & Tube heat exchanger

- ▶ GRAPHITE COLUMNS
- ▶ GRAPHITE EJECTORS
- ▶ GRAPHITE PUMPS
- ▶ ACID DILUTION AND COOLING UNIT
- ▶ SULPHURIC ACID CONCENTRATION UNIT

PROCESS SYSTEMS

- ▶ HCl SYNTHESIS UNIT
- ▶ HCl ABSORPTION UNIT
- ▶ DRY HCl GAS GENERATION UNIT

SERVICES

- ▶ ENGINEERING
- ▶ MAINTENANCE AND REPAIR
- ▶ SUPERVISION OF ERECTION AND COMMISSIONING
- ▶ TROUBLESHOOTING

ACCESSORIES

- ▶ BURSTING / RUPTURE DISC
- ▶ THERMOWELL
- ▶ PIPES & PIPE FITTINGS (Tees, Elbows, Bends, etc.)

We can meet specific requirements:

'U' Stamp (ASME), "CE" marking as per PED/2014/68/EU, Chinese manufacturing license (SELO), KOSHA, DOSH, EAC, SANS 347, Japan Pressure Vessel Class

Graphite Block Heat Exchangers

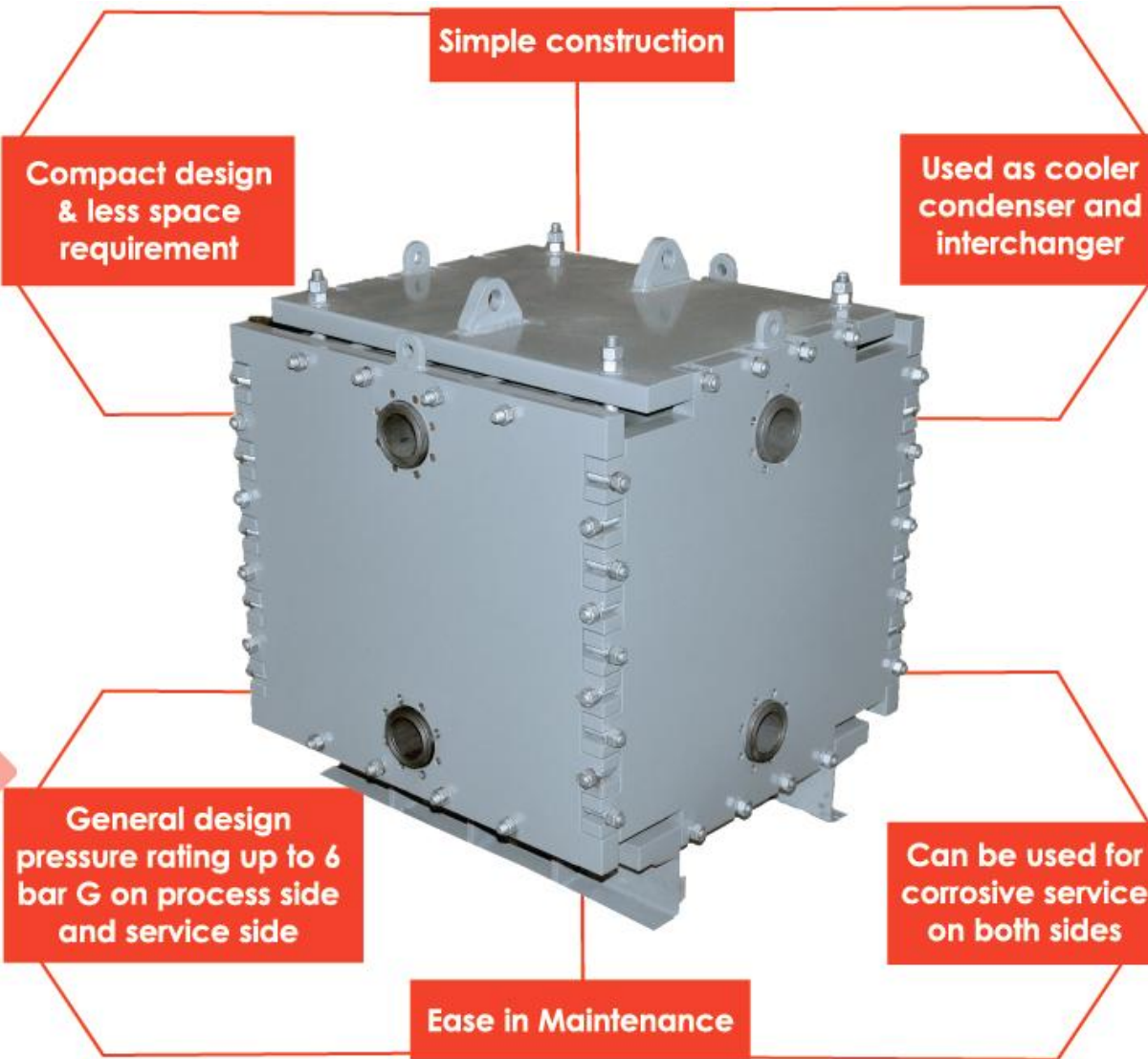

Monoblock Heat Exchanger

Multi-pass arrangement enabling optimized design solution

Impervious Graphite block and Graphite lateral chambers for process fluid

Metallic Lateral chambers for service fluid. (Suitable lining can be provided if required)

Cylindrical Polyblock Heat Exchanger

Surface area can be offered from 0.1 m² up to 1000 m²

Maximum surface area per block – 73 m²

Application and Pressure rating wise around 170 block models to provide optimised solutions

Maximum design pressure rating: 12 bar G / Full vacuum on process and service sides depending on block model (with special design, pressure rating can be increased up to 15 bar G)



Applications as coolers, heaters, condensers, heat interchangers, isothermal falling film absorbers, reboilers, evaporators



Cubical Polyblock Heat Exchanger

Application and Pressure rating wise around 20 block models to provide optimised solutions

Easy maintenance

Maximum design pressure rating up to 11 bar G / Full vacuum on process and service sides depending on block model.

Applications as coolers, condensers, heat interchangers, isothermal falling film absorbers



Shell and Tube type Graphite Heat Exchangers

- Tube sizes available – 7/8" ID x 1 ¼" OD, 1" ID x 1 ½" OD, 1 ½" ID x 2" OD
- Surface area up to 1600 m²
- General Design pressure rating: 9 Bar G / Full vacuum on process and service side depending on requirement.
Higher pressure rating can be offered if required.
- Tubes with carbon fibre reinforcement for improved strength
- Tube sheets with chromium oxide coating to resist erosion due to solid content in Phosphoric acid evaporators



- Impervious Graphite tubes, tube-sheets
- Metallic or Impregnated graphite baffles
- Domes in Impervious graphite or exotic materials (suitable Fluoropolymer or rubber lined carbon steel can be offered if required)
- Metallic shell (suitable Fluoropolymer or rubber lining can be offered if required)



Applications as coolers, heaters, condensers, heat interchangers, isothermal falling film absorbers, reboilers, evaporators, quenchers

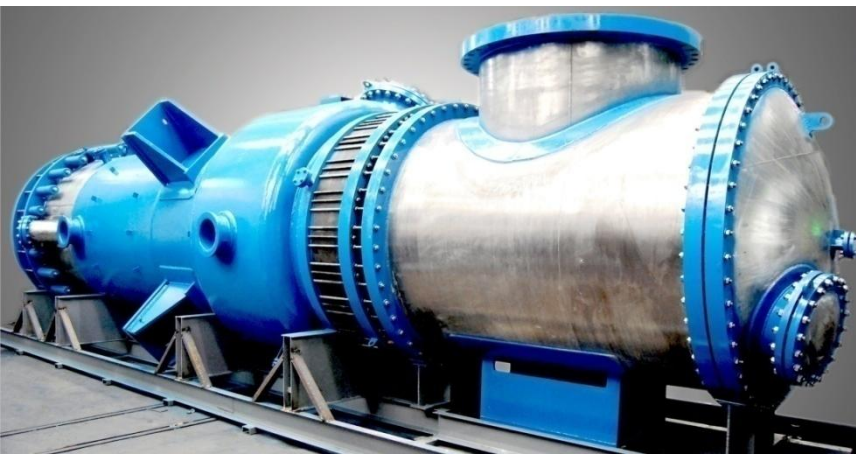

Graphite Columns

- Columns are available in Tray type or Packed type or Combination of both
- Tray types – bubble cap, turbo grid, sieve type
- Packed columns with variety of suitable internals (Ceramic Intalox Saddles, graphite raschig rings)
- Column internal diameter ranging from 100mm ID to 2400mm ID
- General design pressure: 5 Bar G / Full vacuum

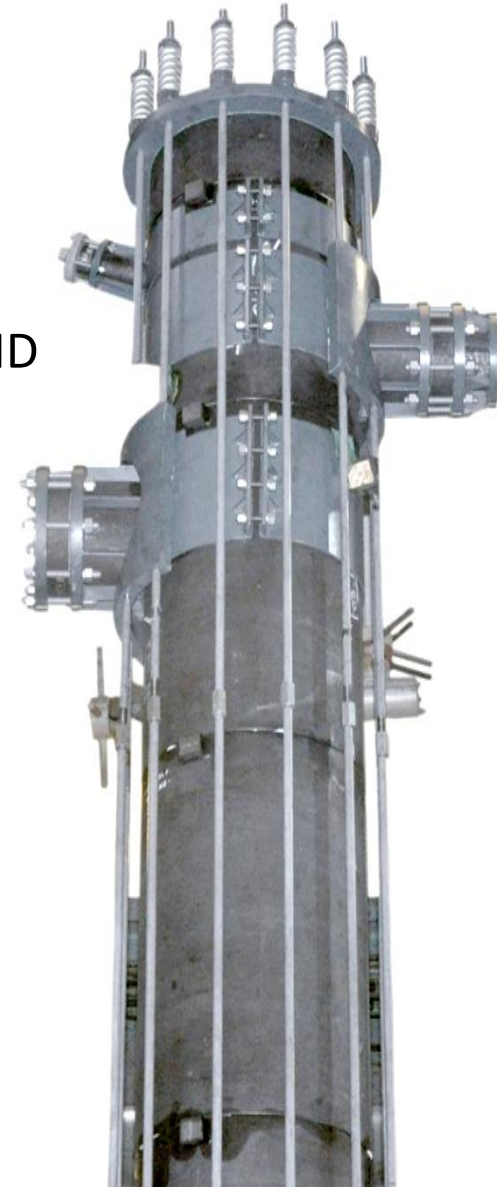

Applications in absorption and distillation

Graphite Ejectors

- Single stage and multi stage depending on vacuum required
- Steam jet and liquid jet
- Capacity to ensure vacuum of 0.5 Torr
- The ejector system can be supplied with surface condensers or mixing condensers
- Skid mounted unit

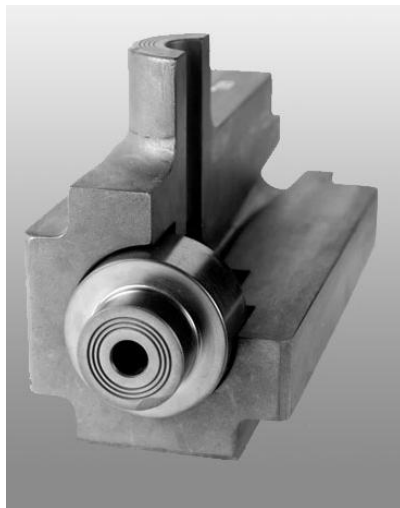

Graphite Pumps

- Flow rates of 1 m³/hr up to 200 m³/hr with a differential head of 40 mtr.
- Single mechanical seal and double mechanical seal (with cooling arrangement)
- All wetted parts are in Graphite



Acid Dilution and Cooling Unit

- Unit is offered for dilution of Sulphuric acid and Hydrochloric acid
- Compact arrangement of mixer, cooler and accessories
- Cooler in Polyblock type or Shell and tube type
- Unit is supplied with necessary accessories

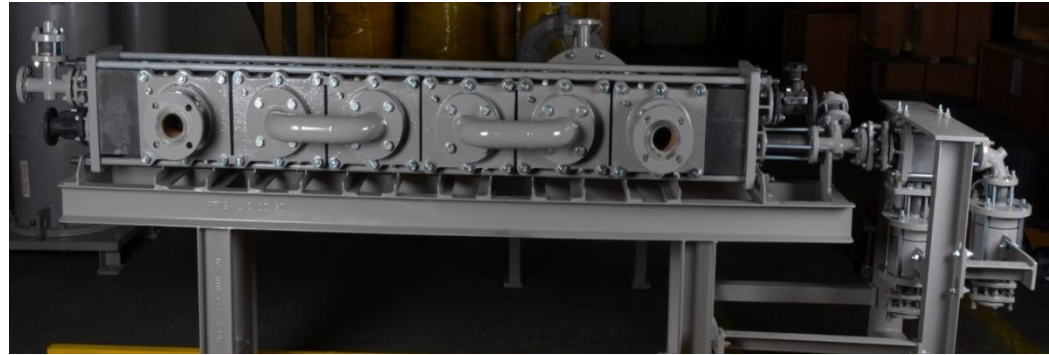

Sulphuric Acid Concentration Unit

- Units are designed and manufactured for producing sulphuric acid of around 70% strength from dilute acid having strength as low as 20%.
- Unit can be single stage or multi stage depending on inlet acid concentration
- Unit consists of thermosiphon reboilers, gas liquid separators, condensers, ejector system, product acid cooler.
- With multiple effect concentration, steam economy can be achieved thereby reducing operating cost.

HCl Synthesis Unit

- Top fired unit to produce commercial grade 30% to 37% Hydrochloric acid with minimum free chlorine content OR Dry HCl gas in Chlor alkali, Paper & pulp, Metal extraction industry.
- Complete skid mounted system consisting of equipment, ancillary equipment, interconnecting piping, instrumentation and necessary automation
- Capacity ranging from 1 TPD up to 200 TPD (100% HCl basis)

FEATURES:

- HCl in vent < 5 ppmv
- Heat recovery in the form of Steam generation
- Automatic start-up
- Start-up with compressed air



Supply of more than 100 HCl Synthesis Units across the globe



Efficient burner design (Impervious Graphite):



- ✚ De-centralized Combustion ensuring efficient mixing & complete combustion of Feed gases
- ✚ Low purities of Chlorine (19 – 21%)
- ✚ Suitable for moist feed conditions
- ✚ Online cleaning / washing facility
- ✚ Cost Effective Solution

HCl Absorption Unit

- Absorption of HCl / HF / HBr gases required in Monochloro benzene / Sulphate of Potash production / MDI-TDI/ CPW etc
- Falling film absorbers in Shell & tube and Polyblock construction
- Product Hydrochloric acid concentration ranging from 5% to 37%
- Absorbers can be designed to handle dilute gas (for less than 2% to 3%)
- Absorption can be continuous as well as in batch operation
- Complete skid mounted system consisting of Falling film absorber, Tail gas tower (Packed bed scrubber), Intermediate tank, Recirculation cum product transfer pump, interconnecting piping, instrumentation and necessary automation

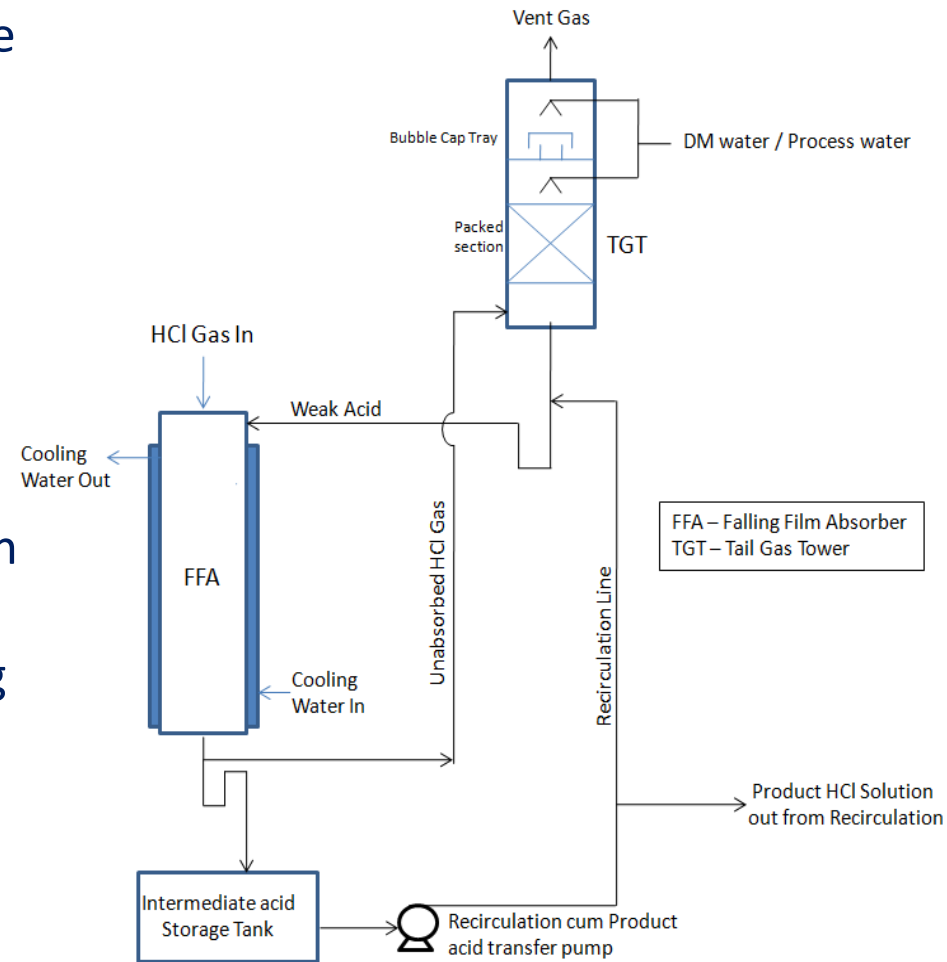

Dry HCl Gas Generation Unit

FEATURES:

- Commercial grade 30% to 38% Hydrochloric acid is used to produce dry HCl gas required in API, chloro-sulphonic acid & speciality chemicals, via 2 routes based on byproduct:

22% HCl Azeotropic Solution Byproduct OR 1% HCl solution Byproduct

- Dry HCl gas purity is more than 99.9%
- Capacity ranging from 25 Kg/hr to 5000 Kg/hr of HCl gas
- Maximum operating pressure of HCl gas produced by 22% HCl solution byproduct route is 3 bar G
- Maximum operating pressure of HCl gas produced by 1% HCl solution byproduct route is 1 bar G
- Complete skid mounted system consisting of equipment, ancillary equipment, interconnecting piping, instrumentation and necessary automation



GRAPHITE INDIA STRENGTH

Understanding customers requirement is our main concern.

THERMAL/PROCESS DESIGN

- A team of Process Designers interact with the customers to know their exact requirement and offer them an optimum solution.
- In-house software's developed on the basis of years of experience, validated design and also HTRI. Personal advise is provided during design stage to get the condition.
- Strength : 6 Engineers

MECHANICAL DESIGN / DRAWING

- A qualified team of Engineers capable to comply with Indian and International Standard.
- Design office is equipped with :
 - i. AutoCAD Software
 - ii. CADWORX
- Strength : Software for mechanical design as per ASME / AD Merkblatt / Stoomwezen
- 3 Engineers and 7 Draftsman

PROJECT ENGINEERING & PLANT AUTOMATION

- Strength : 2 Process Engineers, 2 Instrumentation Engineers

PRODUCTION DEPARTMENT

- High class machinery like Deep Hole Drilling Machine
- Dedicated autoclave for Phenolic and PTFE impregnation
- 24 Hours resin cooling system
- PLC controlled curing cycle
- Automatic Block/Tube testing set up
- A team of experienced Engineers/Supervisors working in shifts
- Strength : 10 Engineers, 60 Technicians

QUALITY ASSURANCE

- Emphasis is always on highest quality standard at all the stages of manufacturing right from raw material identification to finished product, final painting, dispatch.
- Statistical quality control for block drilling
- Extensive component testing if required
- Involvement of Third party wherever necessary
- Implementation of suggestions/feed back from customer and internal people at all levels to ensure and maintain quality.

After sales service

Extensive after sales services comprising:

- Supervision of Erection and Commissioning activities
- Trouble-shooting and Technical support
- Maintenance and repairing of Graphite equipment and systems (on site or GIL workshop)
- Training programs for operating Process systems
- Supply of spare parts



Our Global Customer Base

Asia

- Bangladesh
- China
- India
- Indonesia
- Israel
- Japan
- Jordan
- Lebanon
- Malaysia
- Oman
- Philippines
- Qatar
- Saudi Arabia
- Singapore
- South Korea
- Taiwan
- Thailand
- Turkey

Europe

- Austria
- Belgium
- Denmark
- France
- Germany
- Greece
- Hungary
- Italy
- Netherland
- Norway
- Poland
- Portugal
- Russia
- Spain
- Sweden
- Switzerland
- UK

America

- Argentina
- Brazil
- Paraguay
- Peru
- Uruguay
- USA

Africa

- Algeria
- Egypt
- Morocco
- Senegal
- South Africa
- Tunisia

Australia

- Australia

Highlights

Supply in 50 countries

More than 700 satisfied customers worldwide

Supplied nearly 15000 equipment in India and abroad delivering maximum wear life, reduced life time cost and minimum downtime by means of effective after sales service.

Supplied 125 Turn-key plants worldwide (HCl Synthesis Unit, Dry HCl Gas Generation Unit, HCl Absorption Unit)

More than 300 repeat supplies

Replaced equipment, turn-key systems, spare components supplied by other suppliers at more than 150 sites.

Highlights

Thermal, process and mechanical design, process automation, after-sales services – everything is under one roof.

In-house manufacturing of graphite raw material consisting of mix grain size i.e. fine and coarse thereby making it more flexible and elastic in nature.

Higher thermal conductivity of graphite blocks and tubes

More than 200 blocks models having hole diameters ranging from 8 mm to 35 mm to provide most optimised solutions to process requirement

We can meet specific requirements:

'U' Stamp (ASME), "CE" marking as per PED/2014/68/EU, Chinese manufacturing license (SELO), KOSHA, DOSH, EAC, SANS 347, Japan Pressure Vessel Class

THANK YOU